

## 21. MAINTENANCE AND ADJUSTMENTS RECORD

To ensure continued safe operation and extended life of your opener system, periodic checking for proper operation is necessary. Occasional maintenance and readjustment of your system may also be needed.

MONTHLY:	ONCE EVERY YEAR	AS NEEDED:
<ul style="list-style-type: none"><li>Check reversal system by performing "SAFETY REVERSAL TEST" described in this manual.</li><li>Check proper operation of door by manually moving door open and closed. If door binds or sticks, or is out of balance call for garage door service.</li><li>Check and test photo eye safety system as described in this manual.</li></ul>	<ul style="list-style-type: none"><li>Keep door rollers, hinges, and bearings properly lubricated by following recommended door instructions or contacting a door service company in your area.</li></ul>	<ul style="list-style-type: none"><li>Readjust opener travel limits and force settings as necessary — due to cold weather, normal wear of door, etc. The convenient adjustment instruction label on the opener can be used for any periodic adjustments needed.</li><li>Check and readjust belt tension, if necessary, in the unlikely event that it loses its proper tension during the life of the opener.</li><li>Always check the reversal system after any adjustment of travel limits or forces. A door opener that is not checked could possibly be out of adjustment and be dangerous.</li></ul>

Good maintenance of your garage door is an imperative requirement. Not only will it prolong the life of the door and the opener, but more importantly, it assures your safety and that of others. Use the form below to record the monthly, yearly, and "as needed" maintenance.

Maintenance	Date	Performed By	Comments

If you run out of Maintenance Record lines, please make yourself another record sheet.

© Copyright 2007 All Rights Reserved.  
No part of this manual may be reproduced without our prior written approval.  
We reserve the right to alter details in the interests of progress.



# Garage Door Opener System

## Installation and Operating Instructions

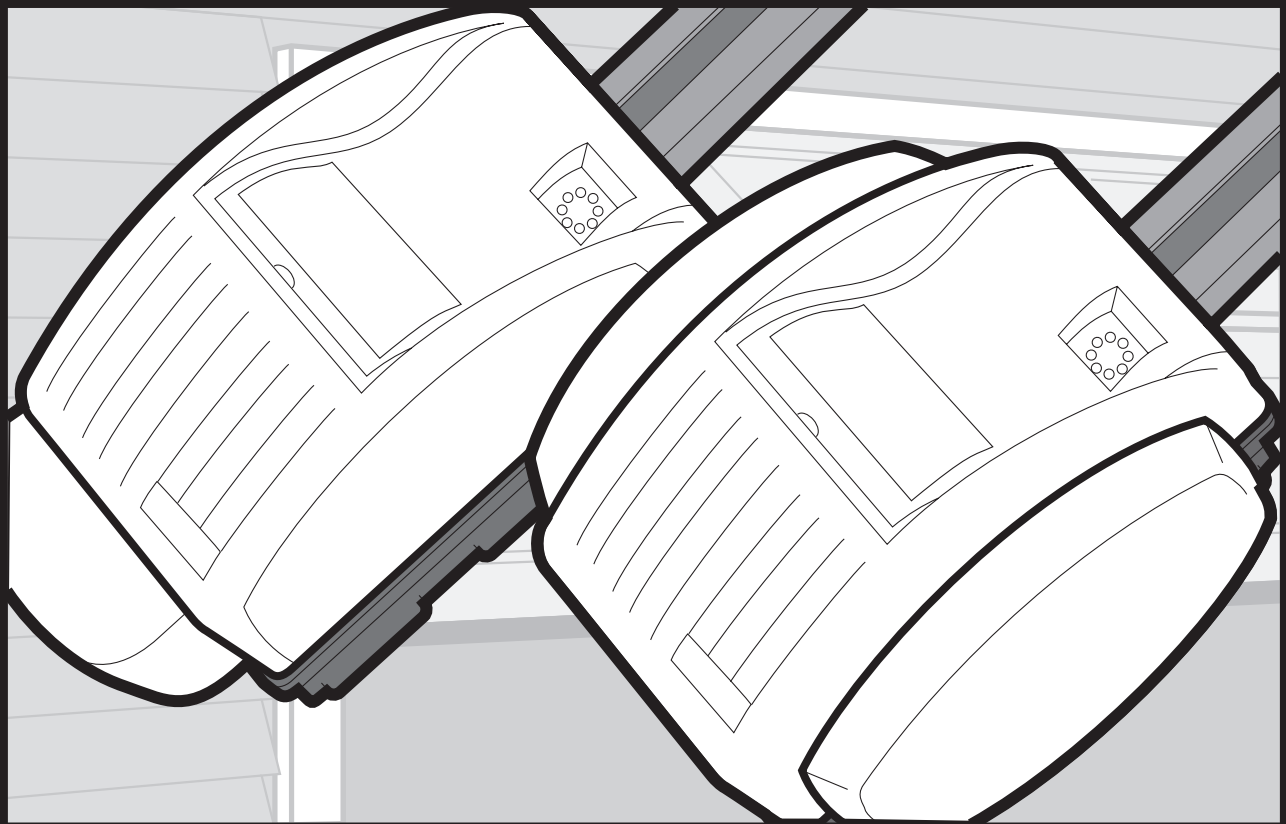

### Deluxe EX-2005 Elite EX-2007

Digital Intelligence for the Garage



Marantec America Corporation  
5705 Centerpoint Court, Gurnee, IL 60031 U.S.A.  
Phone 1-888-622-2489 • Fax 847-478-0348



[www.marantecamerica.com](http://www.marantecamerica.com)

## OWNER'S MANUAL CONTENTS

1. INTRODUCTION	2
2. ADVANCED FEATURES	2
3. IMPORTANT SAFETY INFORMATION	3
4. TOOLS	4
5. GARAGE	4
6. OPENER PACKAGE CONTENTS	6
7. INSTALLATION STEPS	7
8. OPENER PROGRAMMING	15
9. TRANSMITTERS	26
10. OPERATION OF YOUR OPENER	27
11. TEST SAFETY REVERSAL	27
12. TENSION ADJUSTMENT	28
13. RAIL LENGTH ADJUSTMENT - FOR PROFESSIONAL INSTALLERS ONLY	28
14. RAIL ASSEMBLY	29
15. POWER HEAD ASSEMBLY	30
16. ACCESSORIES	32
17. EXTERNAL CONNECTIONS	33
18. TROUBLESHOOTING - FOR PROFESSIONAL INSTALLER ONLY	34
19. ERROR MESSAGES	35
20. TECHNICAL SPECIFICATION	35
21. MAINTENANCE AND ADJUSTMENTS RECORD	36

## 1. INTRODUCTION

Congratulations on purchasing your Marantec® Professional Series Garage Door Opener System, the most innovative opener available today. This stylishly designed digital opener with a wide range of accessories is engineered to provide the smoothest, quietest and safest operation to compliment any home. Advanced technology results in the opener being capable of easily moving almost any properly balanced residential garage door, and at the same time providing state-of-the-art safety features to detect obstructions and to stop and reverse the door, thus helping to protect persons and property near the door.













## 2. ADVANCED FEATURES

This opener includes numerous state-of-the-art features to provide you, the user, with years of trouble-free, convenient, and safe use of your automatic garage door opener.

- **Precision Controlled DC Motor, Complete with Automatic Soft Start and Soft Stop Feature:** The opener automatically detects when your door is almost fully closed or fully opened, and gradually slows the door down before it reaches its fully closed or opened position. During start-up, the door starts moving slowly and gradually ramps up to full speed for the full travel of your door. This reduces the possible damaging effects of the sudden starts and stops associated with some other openers, and results in the smooth operation and increased life of your door and hardware.
- **Built-In Safety Features:** Including patented drive system that delivers only the optimum power needed to move your door safely—Every time!
- **Convenient Status Display:** To indicate the status of your door opener at any time. Especially useful if troubleshooting is necessary.
- **Modular Receiver Concept(patented):** Plug-in your choice of frequency module.
- **Photo Eye Safety System(optional):** State-of-the-art infrared beam system helps detect obstructions in the path of your door and automatically reverses closing door travel, helping to protect persons and property near the door.

## 19. ERROR MESSAGES

When LED  is blinking the error message can be retrieved by pressing  briefly. The total sum of numbers in blinking LEDs indicate so-called error number.

LED flashes erratically	Error number	Fault
	6	Photo eye safety system actuated
	7	Programming not complete
	8	Reference point switch defective
	9	Defective RPM sensor Anti-lock system actuated
	10	Power limit is active
	11	Excess travel stop is active
	15	Photo eye self-monitoring unit not o.k.
	16	Power limit self-monitoring unit not o.k.
	26	Voltage monitoring is active
	27	Response sensitivity of power limit
	28	Learned power limit is active
	35	Electronics defective
	36	NC contact (Terminal 7 & 8) broken

## 20. TECHNICAL SPECIFICATION

### EX-2005 and EX-2007 Series Garage Door Opener

#### Connected loads:

230 V  
250 W (in operation with lighting)  
120 V  
210 W (one light system)

#### Door travel speed:

0.14 m/s with "soft" start and "soft" stop

#### Push and pull force:

500 N  
700 N

#### Excess travel stop:

88 secs.

#### Lighting:

40 W E14 - 230V Application  
60 W E26 - 120V Application

#### Control voltage:

Low voltage below 24 V DC.

#### Automatic timer:

With additional relay for signal lights connection and photo eye to monitor the through-traffic area (both items available as accessories).  
Warning phase adjustable from 2 to 70 seconds.  
Open phase adjustable from 5 – 255 seconds.

#### Automatic cut-out:

Electronic power limit through microprocessor and power sensor.

#### Anti-Block system:

Through microprocessor and RPM sensor.

#### Device to prevent forced opening of door:

Electronic back-drive prevention by permanent protection of the closed door position. Door will automatic close after ca. 1cm detected unauthorized reverse movement.

#### Protection category:

For dry buildings only.

## 18. TROUBLESHOOTING

Fault	Cause	Solution
Indicator 8 does not glow.	No power.	Check mains supply.
	Thermal protection in transformer activated.	Allow transformer to cool down.
	Defective control unit.	Disconnect the electrical power. Remove lamp cover and housing. Unscrew control unit, pull slightly forward and withdraw the connecting plug. Remove control unit and have it checked.
Indicator 6 flashes. Error 10 or 28	Automatic cut out set too sensitively. Door operation too sluggish.	Re-set automatic cut out to be less sensitive (Level 2 Menu 2 & 3 page 20, 21). Make sure door moves easily.
Indicator 6 flashes. Error 6 or 15	External photo eye system defective or interrupted.	Remove obstruction or have photo eye sensors checked.
Door opens but will not close. Error 15	Photo eye system programmed, but not connected (Level 2 Menu 1 page 20).	Reprogram photo eye function or connect photo eye sensors.
No response on impulse. Indicator 7 glows. Error 36	Connecting terminals for "IMPULSE" button bridged, e.g. due to short-circuit or wrong terminal connection.	Temporarily isolate cabled key switches or interior push buttons from control unit. Remove plug, insert plug and look for cable fault.
No response on impulse. Error 36	Short-circuit label removed, but "STOP" button not connected.	Connect "STOP" button.
Transmitter problems	Hand transmitter coding is not consistent with receiver coding.	Check coding Menu 3, page 19.
	Flat battery.	Insert new battery. Flashing LED in transmitter indicates. Flat battery.
	LED 7 does not light up when pressing transmitter button.	Electronic aerial not connected or wrong installation.
	Hand transmitter or control unit defective.	Have both components checked.
Insufficient range of remote control (less than 5 m).	Flat battery in hand transmitter.	Insert new battery. (Flashing LED in transmitter indicates battery condition)
Operator only starts to run shortly. Error 9	RPM sensor defective.	Have operator checked.
	Door too sluggish.	Check door.
Transmitter command does not respond but wall control does (LED 8 on, LED 7 flashes)	Opener is in electronic 'vacation' lock.	Deactivate 'vacation' lock on 3-function wall control or by briefly pressing  button on operator.

## 3. IMPORTANT SAFETY INSTRUCTIONS

This manual is essential to the safe and proper installation, operation, and maintenance of your opener. Read and follow all guidelines and operating instructions before the first use of this product. Store the manual in a safe, easily accessible location.



### IMPORTANT SAFETY INSTRUCTIONS TO REDUCE THE RISK OF SEVERE INJURY OR DEATH:

1. **READ AND FOLLOW ALL INSTRUCTIONS CAREFULLY.**
2. Never let children operate or play with door controls. Keep the remote control away from children.
3. Always keep the moving door in sight and away from people and objects until it is completely closed. **NO ONE SHOULD CROSS THE PATH OF THE MOVING DOOR.**
4. **NEVER GO UNDER A STOPPED, PARTIALLY OPEN DOOR.**
5. Test door opener monthly. The garage door **MUST** reverse on contact with a 40mm (1-1/2") high object laid on the floor. After adjusting either the force or the limit of travel, retest the door opener. Failure to adjust the opener properly may cause severe injury or death.
6. If possible, use the emergency release only when the door is closed. Use caution when using this release with the door open. Weak or broken springs may allow the door to fall rapidly, causing severe injury or death.
7. **KEEP GARAGE DOORS PROPERLY BALANCED.** See Garage Door Owner's Manual. An improperly balanced door could cause severe injury or death. Have a qualified service person make repairs to cables, spring assemblies, and other hardware.
8. Disconnect the electrical power to the garage door opener before making any repairs or removing the housing cover.

### IMPORTANT INSTALLATION INSTRUCTIONS

1. Check with the door manufacturer to determine if additional reinforcement is required to support the door prior to installation of the garage door opener.
2. Install garage door opener only on a properly balanced garage door. An improperly balanced door could cause serious injury. Have a qualified service person make repairs to garage door cables, spring assemblies, and other hardware before installing the opener.
3. Remove all ropes and disable all locks connected to the garage door before installing opener.
4. If possible, install the door opener 2.1m (7 Ft) or more above the floor. Adjust the emergency release cord so that knob hangs 1.8m (6 Ft) above the floor.
5. Do not connect the opener to source of power until this manual instructs you to do so.
6. Locate the wall control panel: (a) within sight of door, (b) at a minimum height of 5 feet above the ground so small children cannot reach it, and (c) away from all moving parts of the door.
7. The Emergency Release Tag must remain on the emergency release cord.
8. After installing the opener, test Safety Reversal System. Door **MUST** reverse when it contacts a 40mm (1-1/2") high object laid on the floor.

*SAVE THESE INSTRUCTIONS for future safety, adjustment, and maintenance purposes.*

## 4. TOOLS

The instructions will refer to the tools shown below for proper installation, adjustment, and maintenance of the garage door opener. Additional tools may be required depending on your particular installation.

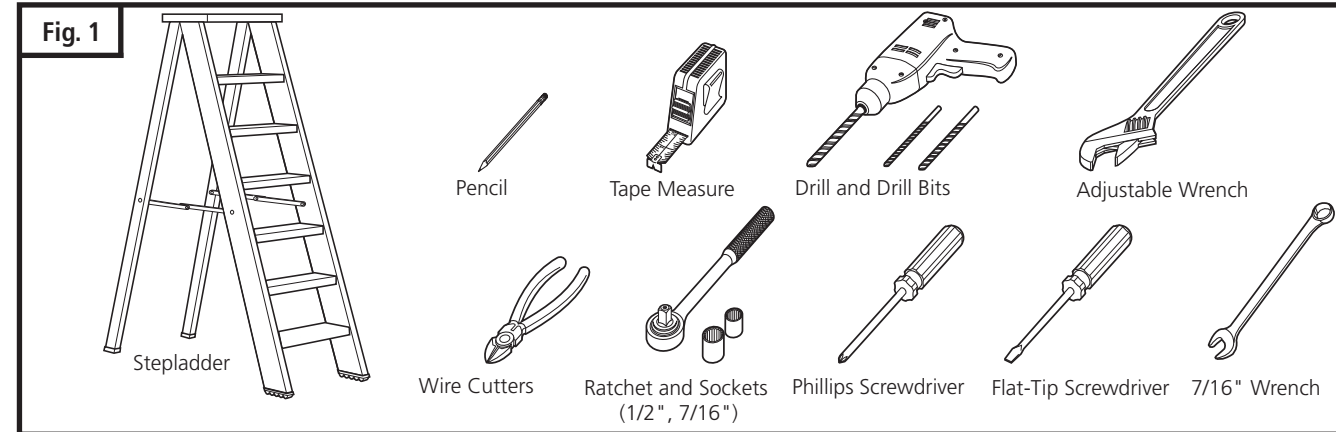

## 5. GARAGE

### ⚠ WARNING ⚠

**A garage door is a heavy moving object and can cause serious injury or death. An unbalanced door might not reverse when required, and can increase the risk of injury. If your garage door is out of balance, or if it binds or sticks, call for professional garage door service. Garage doors, springs, pulleys, cables, and hardware are under extreme tension and can cause serious injury or death.**

**Do not try to adjust them yourself. Ropes left on a garage door could cause someone to become entangled and could kill them. Remove all ropes connected to the door before installing your opener.**

Take a moment to survey your garage and garage door.

- Is there an access door besides the garage door? If not, you should install an emergency key release kit.
- With the garage door closed, check alignment of door and garage floor. The gap, if any, should be no more than 5mm (1/4"). If the gap is larger than this, repair floor or door before installing opener.
- The opener is intended for installation on a properly balanced and adjusted garage door. DO NOT INSTALL IF DOOR IS UNBALANCED OR BROKEN.
- Check balance of door in mid travel and during full range of opening and closing. Lift the door about half way, as shown in Fig. 2 & 3. Release the door. It should remain in place, supported by its springs. Raise and lower the door fully to check for binding or sticking.
- If door is out of balance or needs repair, DO NOT ADJUST IT YOURSELF. CALL A QUALIFIED GARAGE DOOR SERVICE PROFESSIONAL to adjust your door.
- If your door is over 2.1m (7 Ft.) high, you will need a longer rail. See section "6. Rail Assembly" on p. 6 of this manual for availability of longer rails.

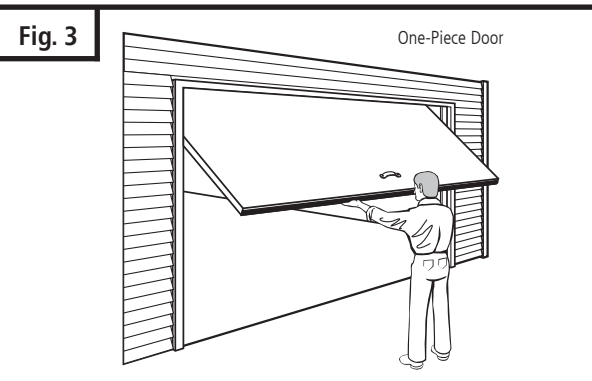
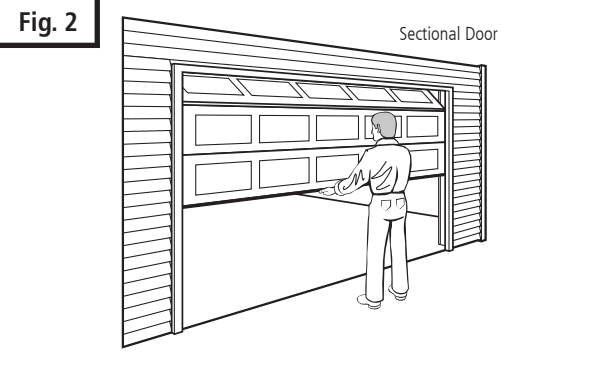

### ⚠ CAUTION ⚠

**To prevent damage to steel, aluminum, fiberglass or glass panel doors, always reinforce the inside of the door both vertically and horizontally with steel or angle iron bracing.**

*The best solution is to follow the instructions for your particular garage door or contact the garage door manufacturer for proper reinforcement instructions.*

## 17. EXTERNAL CONNECTIONS

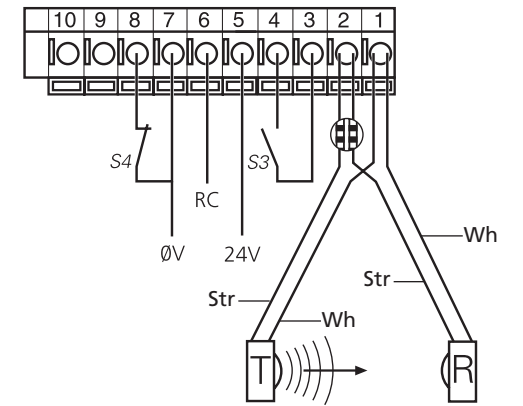
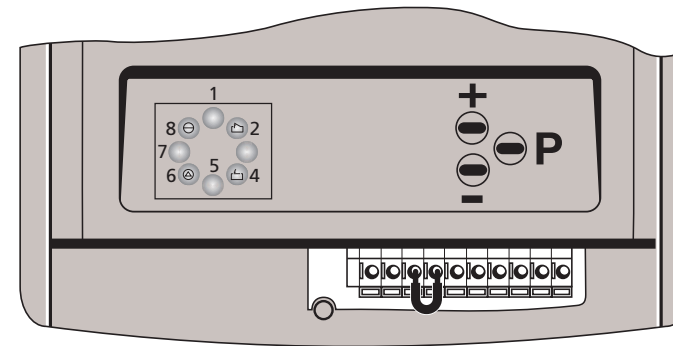

- Xa 2-Prong power cord
- X 3-Prong power cord
- V2 Varistor
- M Motor
- X3A Terminal (motor green lead)
- X3B Terminal (motor brown lead)
- X3C Terminal (motor ground - if applicable)
- T1 Transformer (transformer secondary - 24V)
- X2A/X2B Terminals
- V1 RPM sensor
- S22 Reference point switch
- X4 6 pin terminal (RPM sensor & reference switch connection)
- W20 Receiver RF module
- X1 4 pin terminal (receiver input)
- X5 5 pin terminal (wire harness connection)
- H4/H4a Opener Light(s)
- X6 Relay output contact 1
- ① Internal relay (optional)
- H5 Signal light
- ② External relay (optional)
- S3 Push button impulse
- S4 Push button STOP
- 1-10 Terminal block
  - #1, #2 - photo eye sensors
  - #3, #4 - wall control
  - #5 - 24V DC, 50 ma max.
  - #6 - Relay contact
  - #7 - (OV) Ground
- T(TX) Photo eye transmitter sensor
- R(RX) Photo eye receiver sensor
- bk Black
- bn Brown
- or Orange
- rd Red
- gr Green
- bl Blue
- ye Yellow
- pur Purple
- wh White
- str Stripe

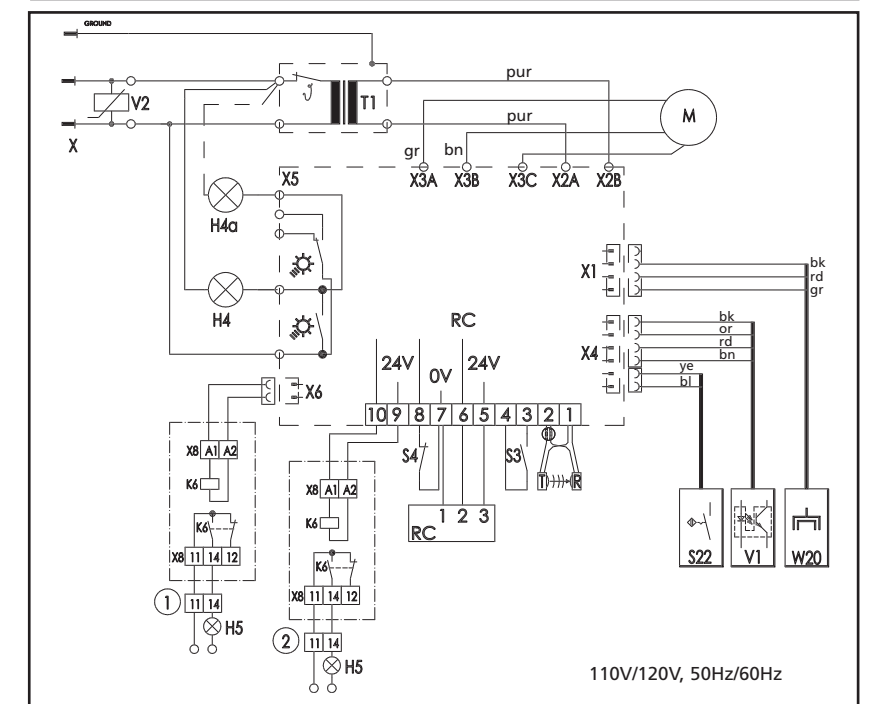
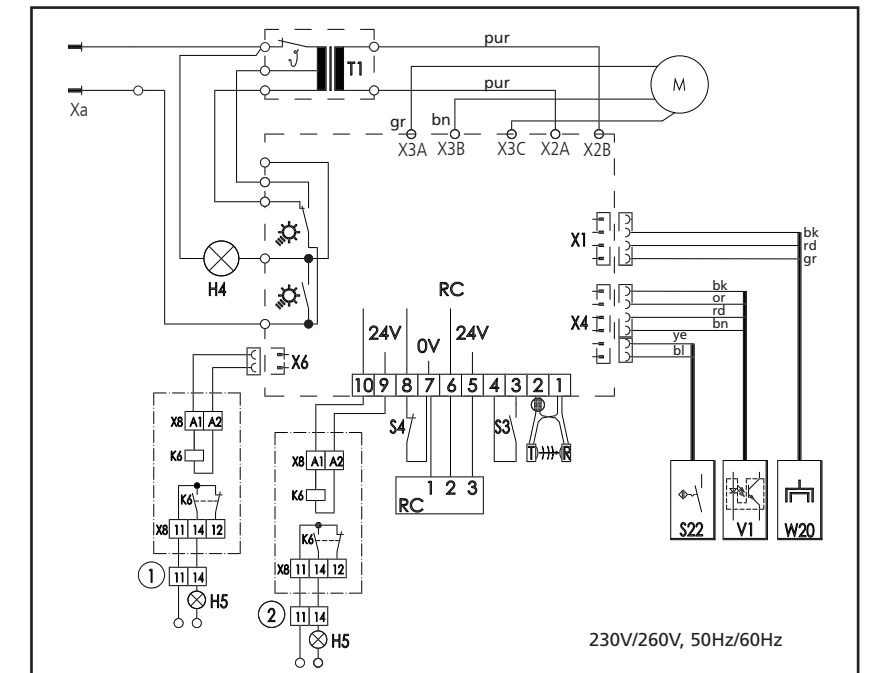



## 16. ACCESSORIES

The following accessories are designed to provide added convenience, satisfaction and value to your door opener system. Accessories are available from your dealer.

Fig. 45

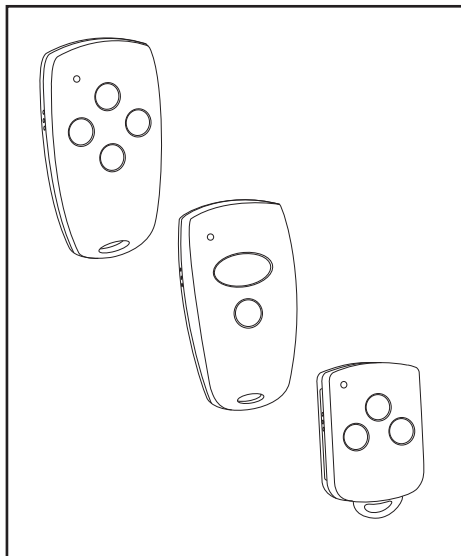

### Mine & Micro Transmitters

- Advanced multibit technology for better, more secure signal transmission.
- Battery included.
- Complete with visor clip.

### MINI

2 Channel Model#: M3-2432X

4 Channel Model#: M3-2434X

### MICRO

3 Channel Model#: M3-3433X

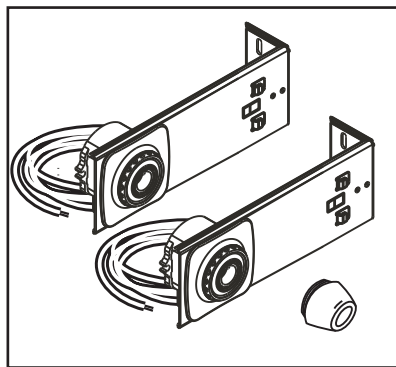

### Photo Eye Safety System

- Provides a system of protection for you and your family.
- Designed to suit your particular garage. Model#: M4-705

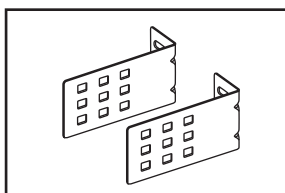

### Extension Bracket Kit

- Hardware included Part#: 72802

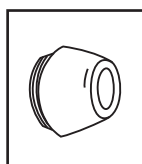

### Lens Sunshield Extension

Part#: 73536

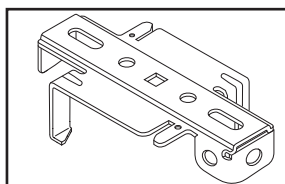

### Support Bracket

- Helps support rail 13' and longer. Part#: 71865

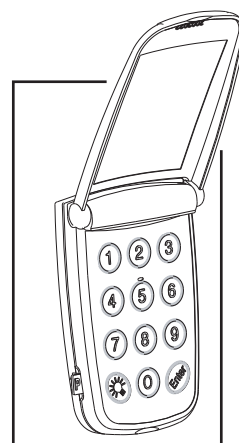

### Wireless Keyless Entry System

- Permits control of garage door opener from outside without keys.
- 4-digit security PIN.
- Battery Included.
- Complete with mounting hardware. Model#: M3-643X

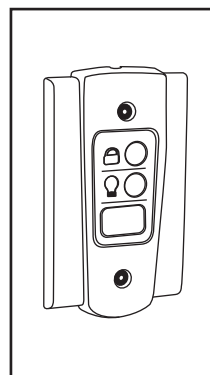

### Wall Control Panel

- Provides control buttons for Light and Vacation/Lock function.
- Illuminated door Pushbutton for easy locating in dark.
- Mounting hardware and wire included. Model#: M3-543

## 5. GARAGE (cont'd)

Check the type of door construction you have. The information contained in the figures below will be referred to later in the manual for proper installation on the different door types.

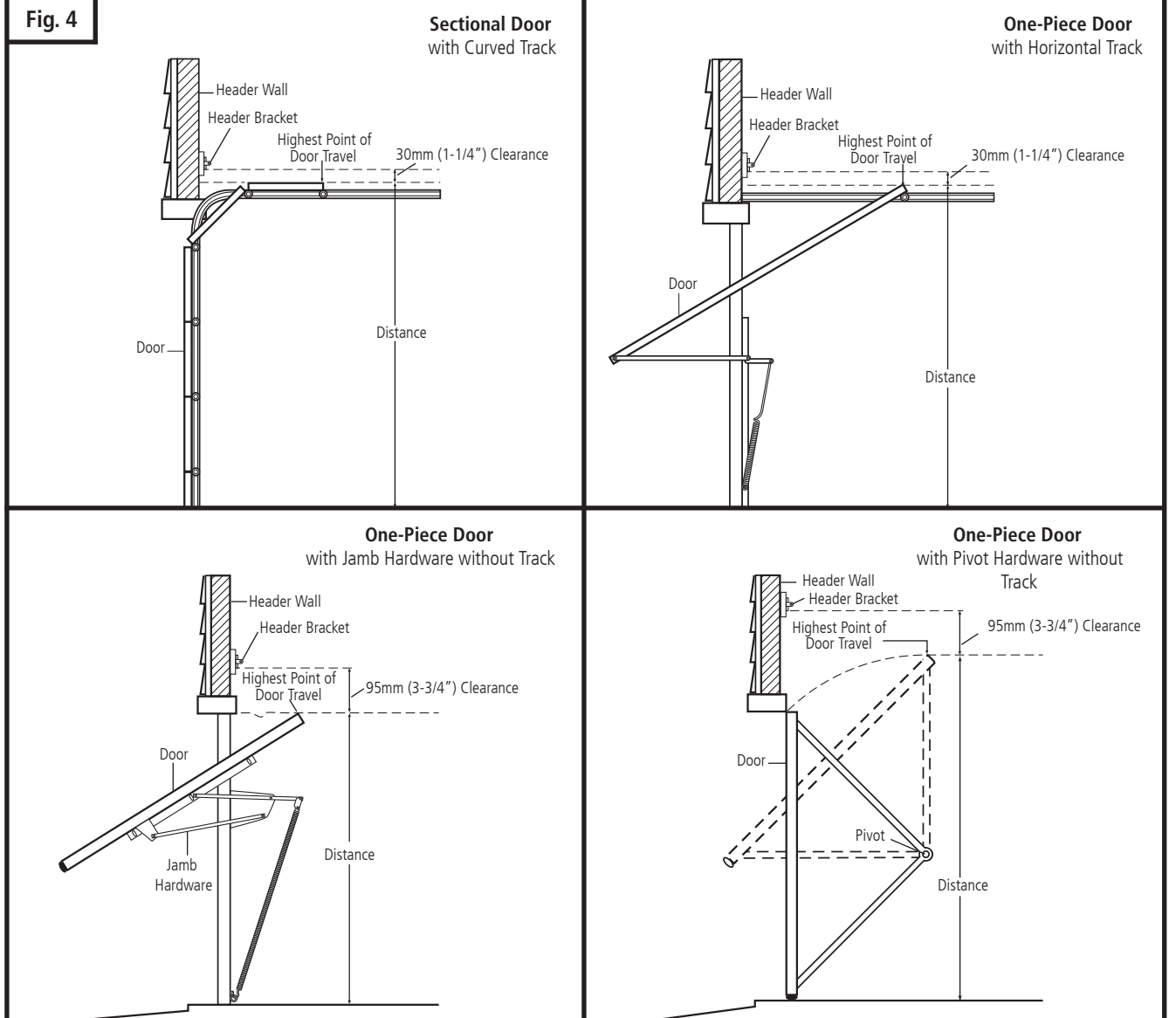

### GARAGE DOOR OPENER SYSTEM OVERALL DIMENSIONS 2.1m (7ft) DOOR

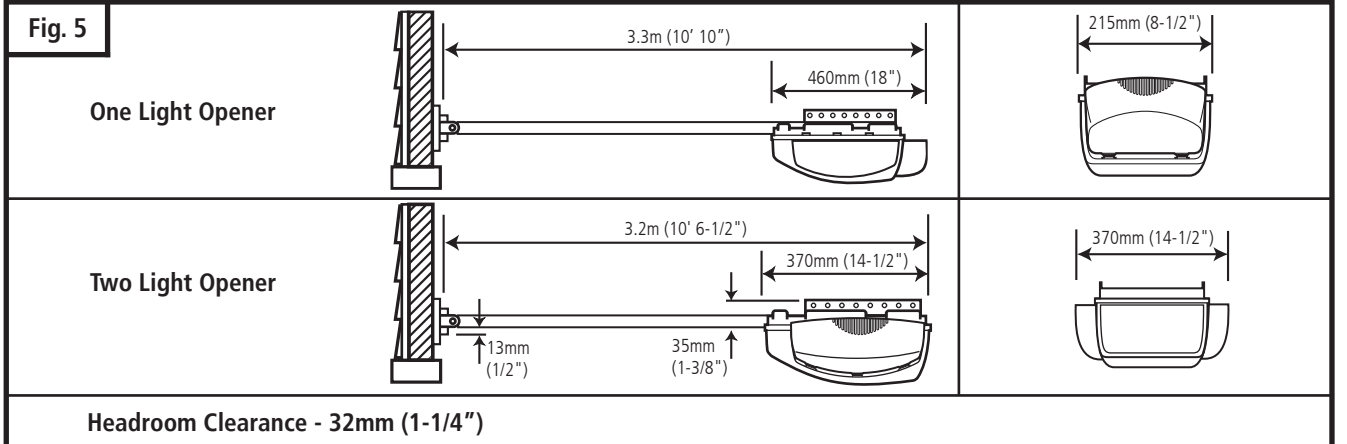

## 6. OPENER PACKAGE CONTENTS

The following items are included with your Garage Door Opener. All hardware components are located in the GDO carton. The accessories are packaged with their respective hardware in separate packs for ease of identification and use.

Items shown not actual size.

**Fig. 6 POWER HEADS**

**EX-2005**  
(One-Light Opener)

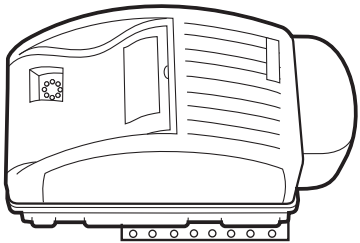

**EX-2007**  
(Two-Light Opener)

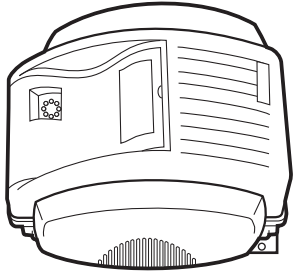

**Fig. 7 ACCESSORIES**

**Pushbutton (with Hardware Kit)**  
(For EX-2005)

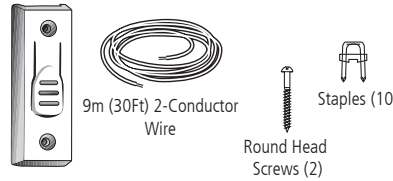

9m (30Ft) 2-Conductor Wire  
Round Head Screws (2)  
Staples (10)

**4-Channel Mini Transmitter (with Accessory Kit)**

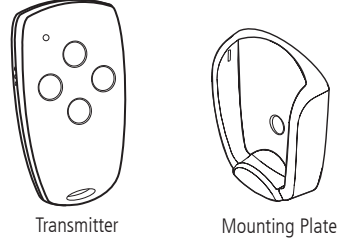

Transmitter  
Mounting Plate  
Visor Clip  
Programming Connector  
Cover

**Wall Control Panel (with Hardware Kit)**  
(For EX-2007)

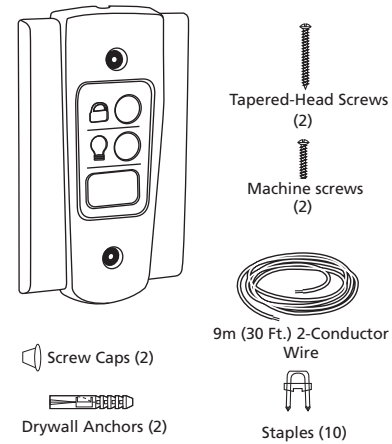

Tapered-Head Screws (2)  
Machine screws (2)  
Screw Caps (2)  
Drywall Anchors (2)  
9m (30 Ft.) 2-Conductor Wire  
Staples (10)

**HARDWARE KIT**

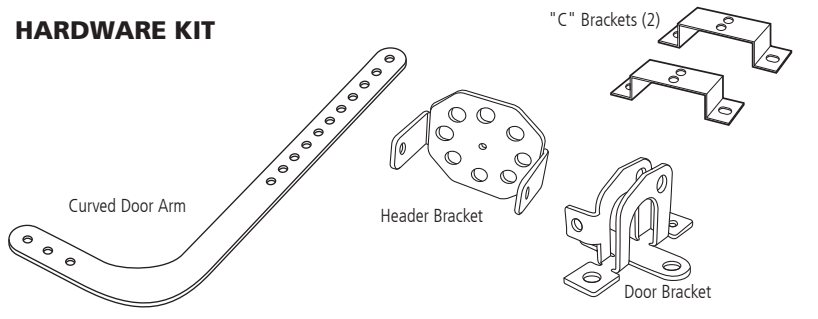

- Plastite Screw (4): 6 X 14
- Clevis Pin (1): 5/16" x 7/8" Cotter Ring (1)
- Clevis Pin (1): 1/4" x 3-1/4" Cotter Ring (1)
- Carriage Bolt (2): 1/4" - 20 x 2"
- Lock Washer (2): 1/4"
- Hex Nut (2): 1/4" - 20
- Lag Screw (2): 5/16" x 1-5/8"
- Lag Screw (4): 1/4" x 1-1/2"
- Hex Bolt (2): 5/16" - 18 x 3/4"
- Lock Nut (2): 5/16" - 18
- Hex Head Tek Screw (2): 1/4 x 3/4"

**Fig. 8 RAIL ASSEMBLY**  
(packaged in separate carton)

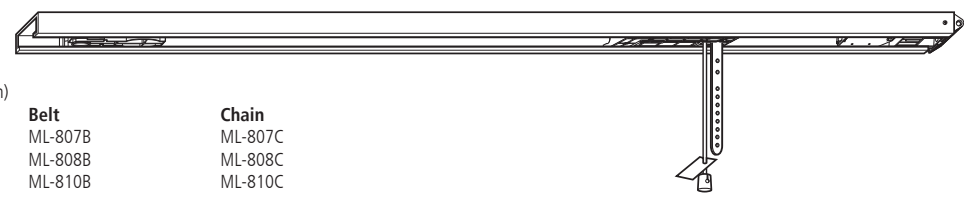

**Models (per application)**

	<b>Belt</b>	<b>Chain</b>
2.1m (7') Door	ML-807B	ML-807C
2.4m (8') Door	ML-808B	ML-808C
3m (10') Door	ML-810B	ML-810C

## 15. POWER HEAD ASSEMBLY (cont'd)

Fig. 44

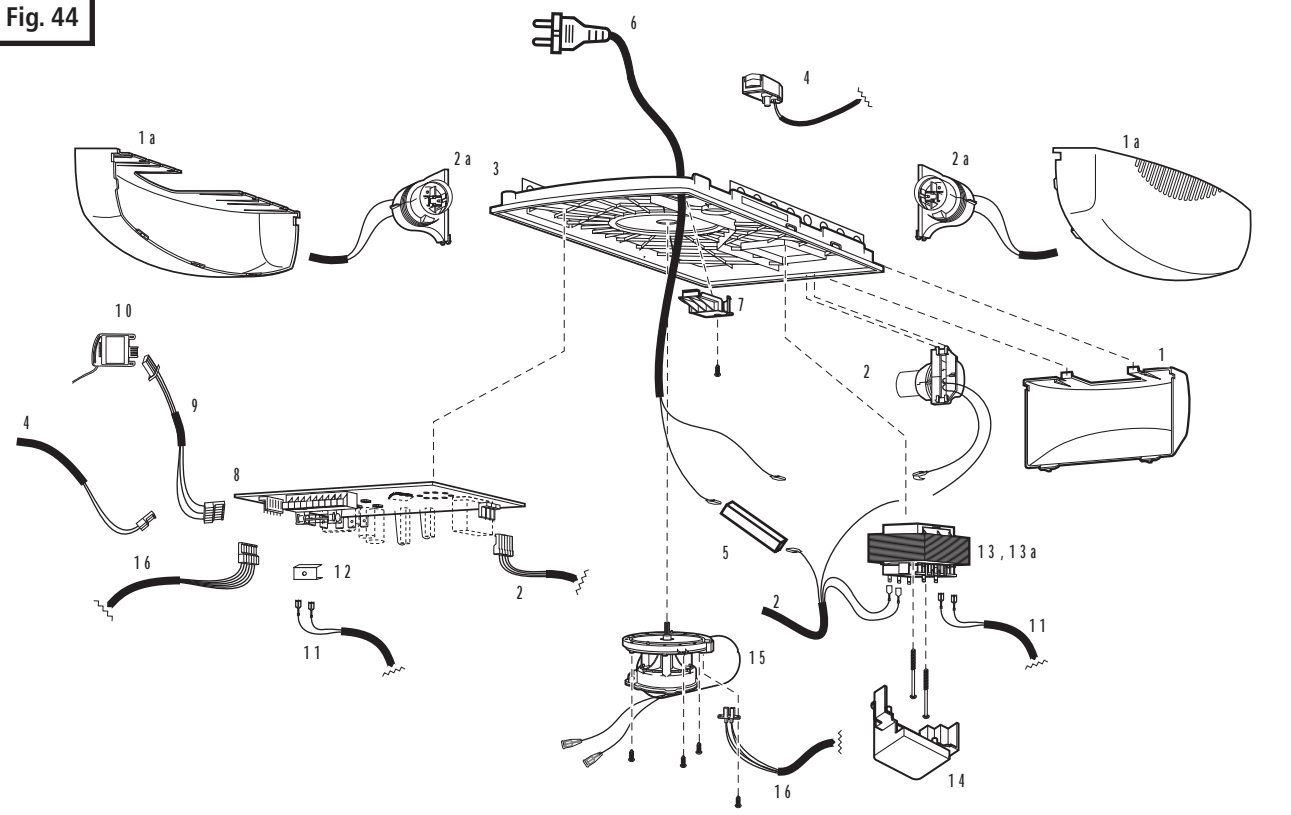

**EX-2005 - 220**

Item	Part #	Description
1	8030590	Lamp Lens
2	8009966	Wire Harness
3	—	Chassis Assembly
4	8054389	Reference Switch
5	8011196	Connector
6	8053601	Power Cord
7	8007776	Strain Relief Cover
8	65627	Logic Board
9	8015077	Connector Cable
10	ML-843	Modular Receiver
11	8008470	Cable (TR to LB)
12	60379	Clip
13	8008513	Transformer
14	8011071	Cover
15	73894	Motor Assembly
16	8055529	RPM Sensor w/Wire Harness
17	8030410	Housing Assembly
18	8030412	Cover with Label

**EX-2007 - 220**

Item	Part #	Description
1a	8030589	Lamp Lens
2a	8051676	Wire Harness
3	—	Chassis Assembly
4	8054389	Reference Switch
5	8011196	Connector
6	8053601	Power Cord
7	8007776	Strain Relief Cover
8	65627	Logic Board
9	8015077	Connector Cable
10	ML-843	Modular Receiver
11	8008470	Cable (TR to LB)
12	60379	Clip
13a	8004852	Transformer
14	8011071	Cover
15	73894	Motor Assembly
16	8055529	RPM Sensor w/Wire Harness
17a	8030410	Housing Assembly
18a	8030413	Cover with Label

## 15. POWER HEAD ASSEMBLY

Fig. 43

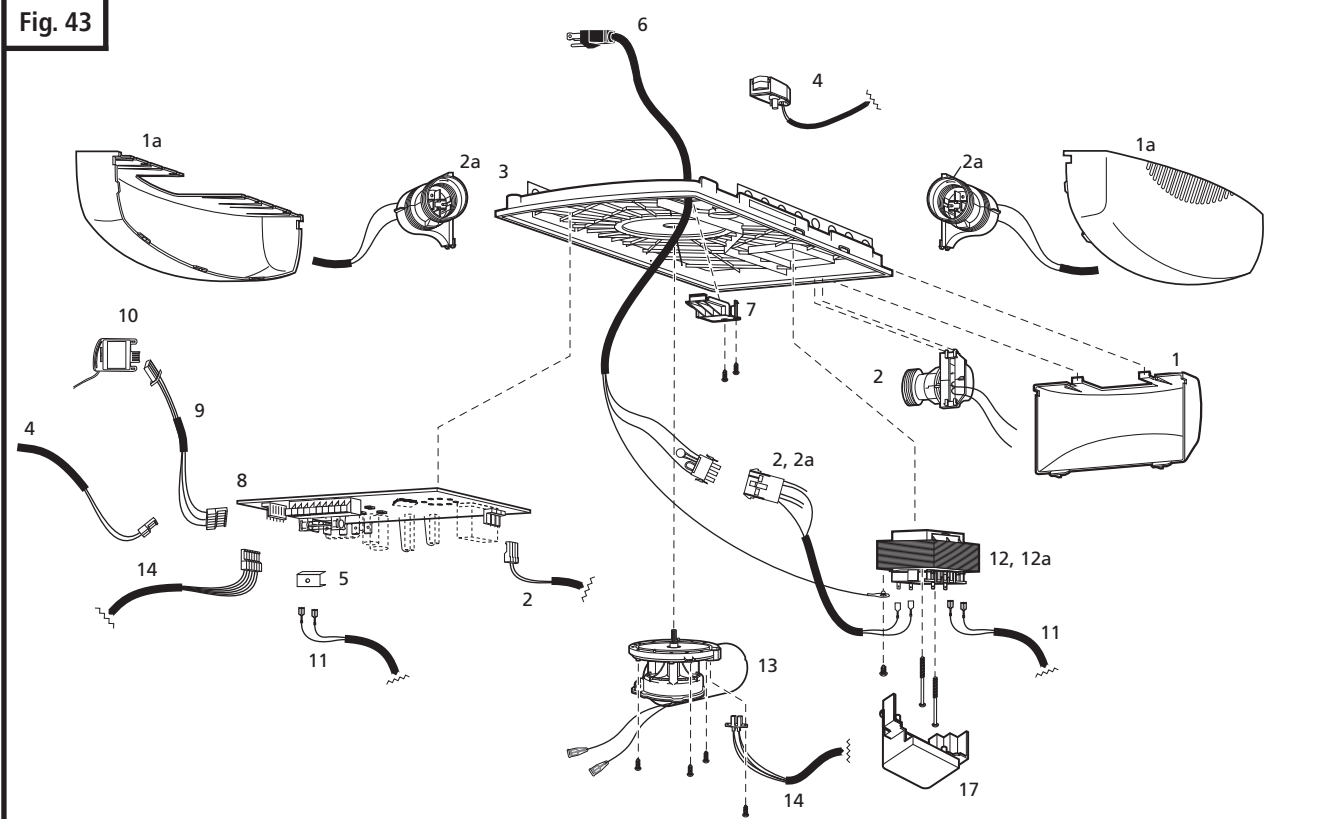

EX-2005 - 110

Item	Part #	Description
1	8030590	Lamp Lens
2	8030990	Wire Harness
3	—	Chassis Assembly
4	8054389	Reference Switch
5	60379	Clip
6	8030987	Power Cord
7	8007776	Strain Relief Cover
8	65627	Logic Board
9	8015077	Connector Cable
10	ML-843	Modular Receiver
11	8008470	Cable (TR to LB)
12	8008474	Transformer
13	73894	Motor Assembly
14	8055529	RPM Sensor w/Wire Harness
15	8030422	Housing Assembly
16	8030412	Cover with Label
17	8011071	Cover

EX-2007 - 110

Item	Part #	Description
1a	8030589	Lamp Lens
2a	8030991	Wire Harness
3	—	Chassis Assembly
4	8054389	Reference Switch
5	60379	Clip
6	8030987	Power Cord
7	8007776	Strain Relief Cover
8	65627	Logic Board
9	8015077	Connector Cable
10	ML-843	Modular Receiver
11	8008470	Cable (TR to LB)
12a	8003273	Transformer
13	73894	Motor Assembly
14	8055529	RPM Sensor w/Wire Harness
15a	8030421	Housing Assembly
16a	8030413	Cover with Label
17	8011071	Cover

## 7. INSTALLATION STEPS

Identify a sound structural support on header wall above garage door for header bracket mounting. See Fig. 10. If appropriate header does not exist, replace or install a new support using a 50x100mm or 50x150mm (2x4 or 2x6) board. Fasten it securely using lag screws (not provided) to structural supports of garage.

### 7-1. MEASURE AND MARK DOOR AREA

Before starting your installation, the door and the header above the door must be measured and marked. This way, the appropriate brackets can be mounted at the correct locations avoiding installation and operating difficulties later.

#### MARK VERTICAL CENTER LINE:

- Measure door width, then locate the center point (Fig.9).
- Mark a vertical line on the upper half of your door, on the top edge of your door, and on the header, through the center point.

#### MEASURE DOOR'S HIGHEST TRAVEL POINT:

(Review Figs. on p. 5 for details)

- Open door to its highest travel point and measure from the garage floor to the top of door.
- Write down this distance.

#### FOR SECTIONAL DOORS AND ONE-PIECE DOORS WITH HORIZONTAL TRACK:

Add 30mm (1-1/4") to the door travel height (measured above).

#### FOR ONE-PIECE DOORS WITHOUT TRACK:

Add 95mm (3-3/4") to the door travel height (measured above).

#### MARK HORIZONTAL LINE FOR HEADER BRACKET LOCATION:

- Close door and measure the required distance (determined above) from the garage floor to the header.
- Mark a horizontal line, intersecting the vertical center line, on header. This is the position at which the bottom of the header bracket should be installed.
- In case of minimal clearance above the door, the header bracket may be mounted to the ceiling. In this case, extend the vertical center line onto the ceiling, and mark a horizontal line on the ceiling no further than 100mm (4") from the header wall. The header bracket should be mounted no farther than this distance from the header wall.

### 7-2. INSTALL HEADER BRACKET

#### WARNING

*If the header bracket is not rigidly fastened to a sound structural support on the header wall or ceiling, the safety reverse system may not work and could cause serious injury or death. DO NOT move or adjust springs or garage door hardware, as these parts are under extreme tension and could cause injury or death.*

Fig. 9

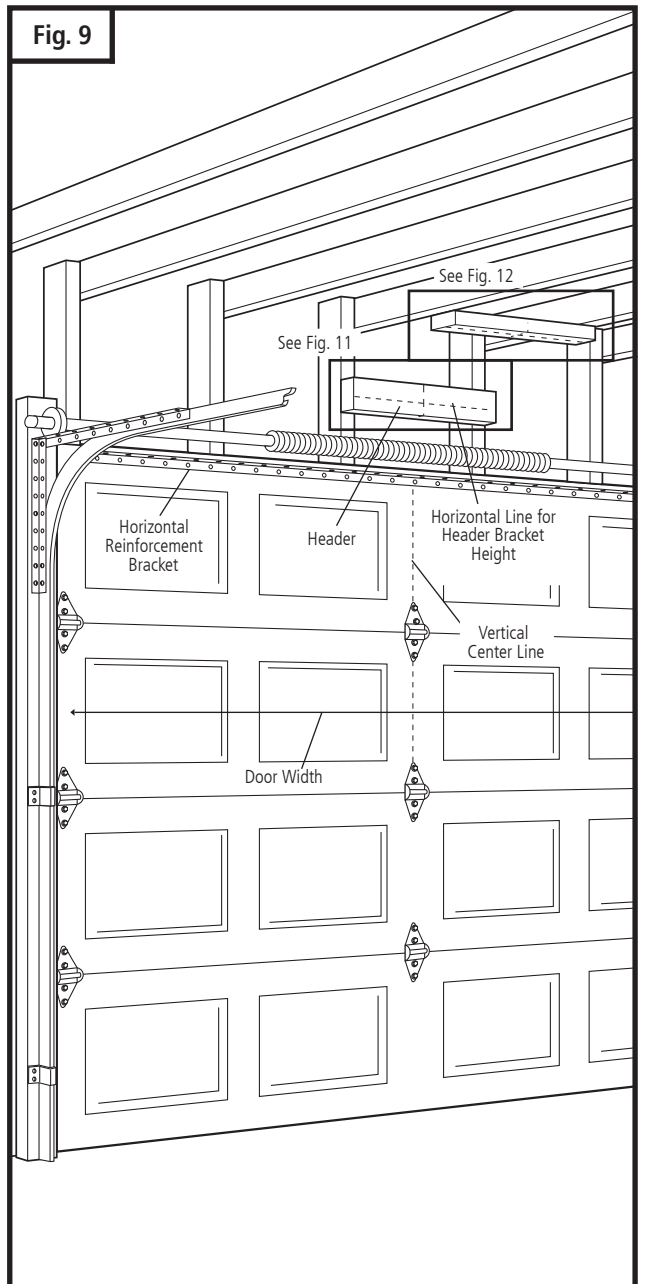
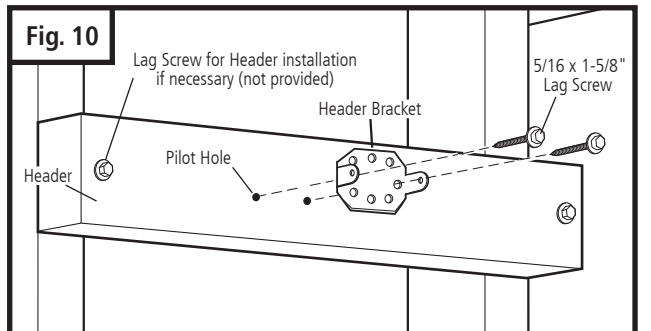

Fig. 10



## 7-2. INSTALL HEADER BRACKET (cont'd)

- Mark pilot holes location on header through header bracket holes where lag screws will be inserted.
- IMPORTANT:** See Fig. 10 for which header bracket holes to use.
- Drill 3/16" pilot holes into header, and install bracket with lag screws (5/16 x 1-5/8") provided.
- Tighten lag screws firmly.

**NOTE:** Follow the same procedure if header (shown in Fig. 11) runs vertically instead of horizontally and is the only option for mounting header bracket to header wall. In case of minimal clearance above the garage door, the header bracket may be mounted to the ceiling. Follow the same steps above to ensure a sound surface for mounting.

## 7-3. INSTALL DOOR BRACKET TO DOOR

### A. FOR SECTIONAL DOORS: Wood Sectional Doors (Fig. 13)

- Position door bracket (Fig. 13) along vertical center line of door with pin hole facing top of the door and top edge of the bracket 100mm (4") to 125mm (5") below top edge of the door, or roughly at the same height as top rollers on the door.
- Mark locations of securement holes through door bracket.
- Drill two 1/4" holes through door for securement of door bracket.
- Insert carriage bolts (1/4" x 2") from the outside through door and bracket, then secure with lock washers and nuts from the inside.
- Tighten nuts firmly.

### Metal Sectional Doors

- Attach door bracket with two teck screws (provided) per Door manufacturer recommendations.

### B. FOR ONE-PIECE DOORS:

Before starting the installation of the door bracket, cut off mounting leg from opposite side of pin hole.

#### One-Piece Doors with Exposed Frames (Fig. 14)

- Position center of door bracket on the center line on the top edge of door.
- Mark the position where carriage bolts will go through bracket, and drill two 1/4" holes through top frame of door.
- Install carriage bolts from the bottom, through door frame and bracket, and secure with lock washer and nut from top.
- Tighten nuts firmly.

#### One-Piece Doors without Exposed Frames (Fig. 14A)

- For doors without exposed frames, use alternate method of mounting door bracket.
- Mark and drill two 3/16" pilot holes into top of frame, then secure bracket with 5/16" x 1-5/8" lag screws (not provided).

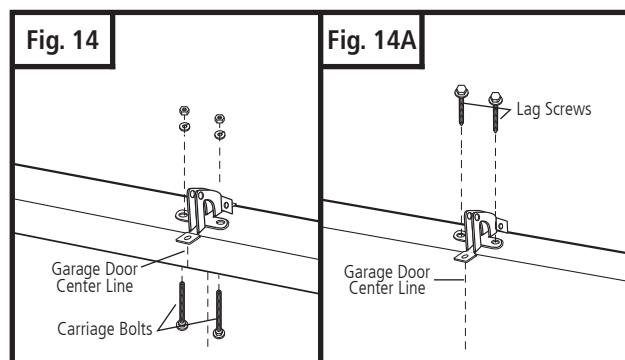
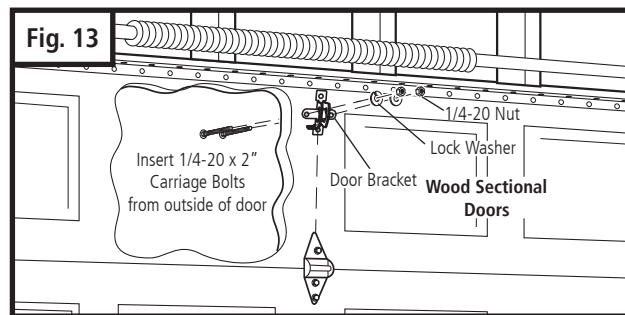
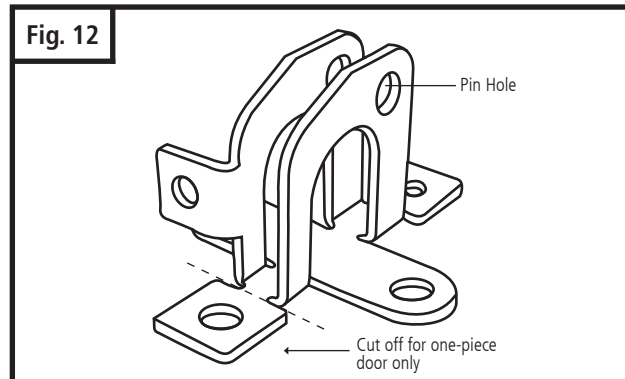
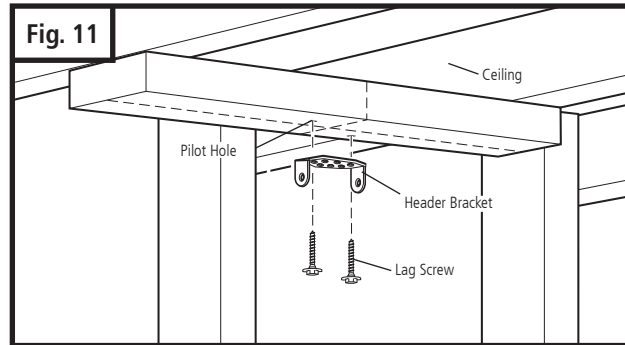

One-Piece Door with Exposed Frame: Install with Carriage Bolts

One-Piece Door without Exposed Frame: Install with Lag Screws(not provided)

## 14. RAIL ASSEMBLY

Fig. 41

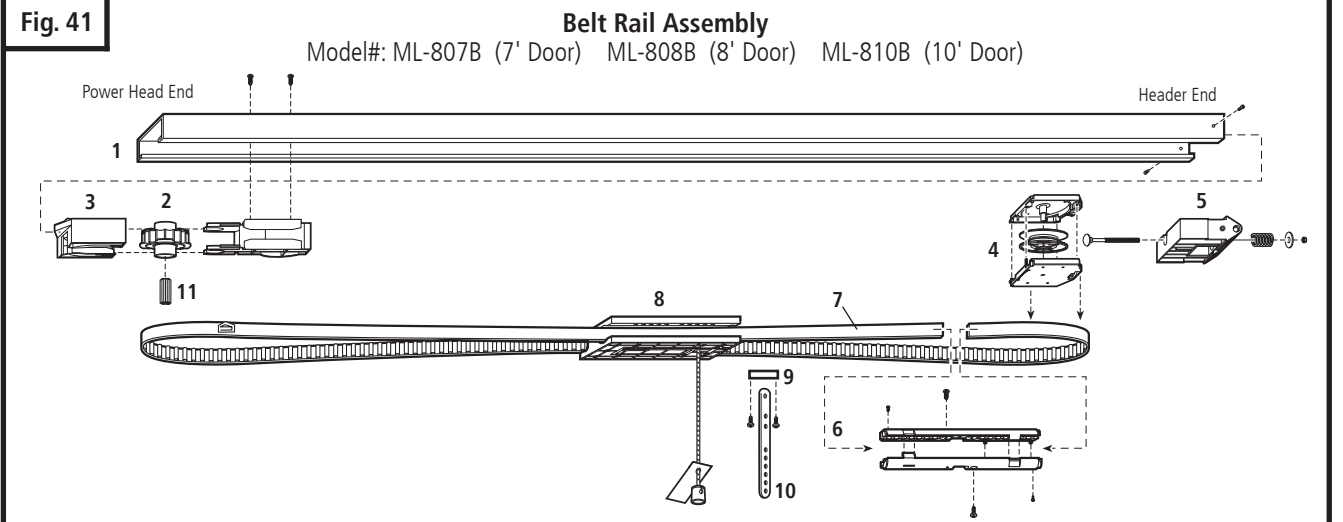

Item Part #	Description	Item Part #	Description
1.	— Rail	7.	Belt with position tab
2.	8030337 Sprocket holder assembly	8.	8030177 Trolley assembly (7' Door)
3.	8008709 Belt guide	8030178	Trolley assembly (8' & 10' Door)
4.	8030432 Roller holder with tension bolt assembly	9.	8008708 Pin
5.	8008503 Rail end-stop	10.	8030735 Straight door arm
6.	8030196 Belt connector	11.	8007412 Shaft adapter

Fig. 42

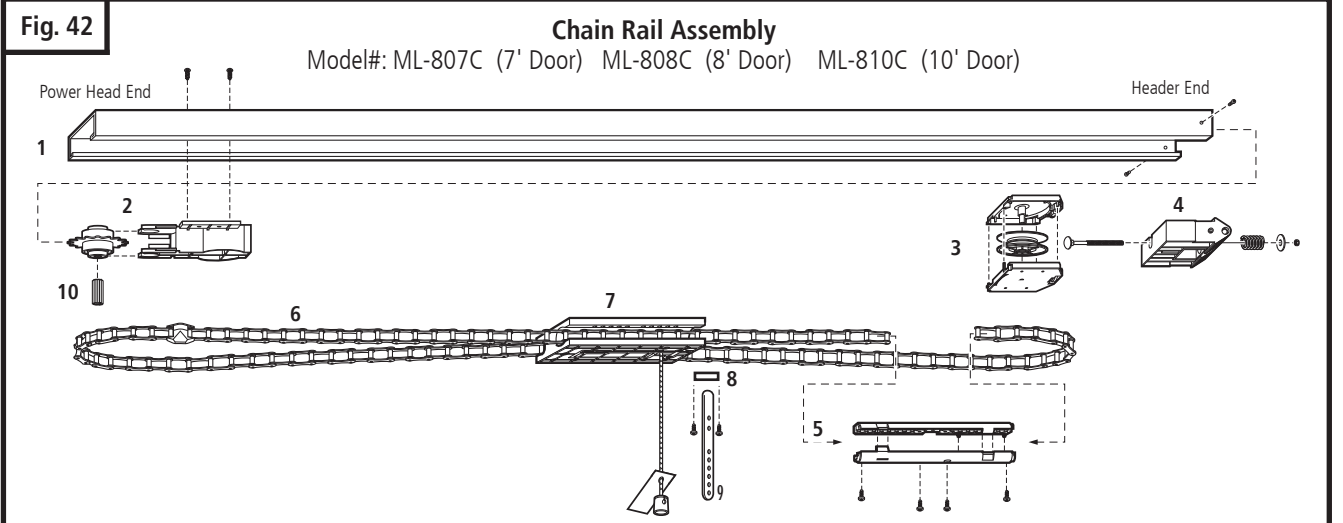

Item Part #	Description	Item Part #	Description
1.	— Rail	7.	8030177 Trolley assembly (7' door)
2.	8030339 Sprocket holder assembly	8030178	Trolley assembly (8' & 10' Door)
3.	8030432 Roller holder with tension bolt assembly	8.	8008708 Pin
4.	8008503 Rail end-stop	9.	8030735 Straight door arm
5.	8030234 Chain connector	10.	8007412 Shaft adapter
6.	— Chain with position tab		



## 12. TENSION ADJUSTMENT

Your preassembled rail comes with the tension adjusted to factory specifications. There should be no need for further adjustment. However, if exposed or subjected to unusually harsh operating conditions, the tension may need to be readjusted during the life of the opener.

### CHECK PROPER TENSION (Fig. 38):

- Release trolley from belt or chain, then examine the setting of the tension adjustment at the header end of the rail.
- Proper tension is set when the tension nut is tightened just enough so that the washer will be spaced approximately 1mm or 3/64" from the stationary rail end-stop arch.
- If the gap between the washer and the rail end-stop arch is too big or too small, the tension needs to be adjusted.

### ADJUST THE TENSION:

- To increase the tension and tighten the belt or chain, turn the tension nut clockwise with 7/16" wrench until the washer is spaced properly from the rail end-stop arch. See Fig. 38.
- Once the washer is spaced correctly, any additional tightening will overtighten the belt or chain and may cause damage to the system.
- To loosen the tension, turn nut counterclockwise.
- Reattach trolley.

## 13. RAIL LENGTH ADJUSTMENT

### FOR PROFESSIONAL INSTALLERS ONLY

If your particular installation calls for a shorter rail than the standard length provided, it is possible to shorten the rail.

**NOTE:** Shortening rail too much may result in door travel length reduction and door not opening fully. This depends on door size and configuration. Carefully plan all such modifications before proceeding. **THIS PROCEDURE SHOULD BE PERFORMED ONLY BY A PROFESSIONAL INSTALLER FULLY FAMILIAR WITH THIS TYPE OF OPENER SYSTEM.**

### TO SHORTEN BELT RAIL LENGTH:

- Loosen belt tension as much as possible.
- Remove screws from sprocket holder and rail end-stop.
- Slide belt and all rail parts out of rail from header end. See rail exploded view, Fig. 41 on p. 29, for disassembly details.
- Measure and cut off excess rail from header end.
- Using rail end-stop as a guide, mark and drill two 3/16" holes on rail sides for rail end-stop screws.
- Disassemble connector to expose free ends of belt.
- Using the same measurement as the excess rail length, cut the same amount off BOTH free ends of the belt.
- Reassemble belt connector, and slide all rail parts into rail from header end according to original assembly (Fig. 38 and Fig. 39).
- Tension belt properly (Fig. 38).
- Check rail for proper assembly and operation by manually moving trolley from end to end and back to position per Fig. 39, with trolley connected to belt.

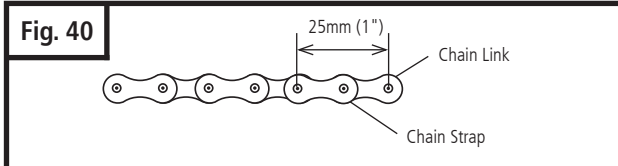
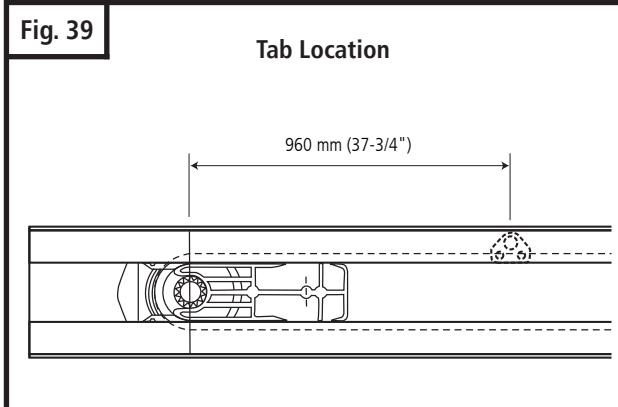
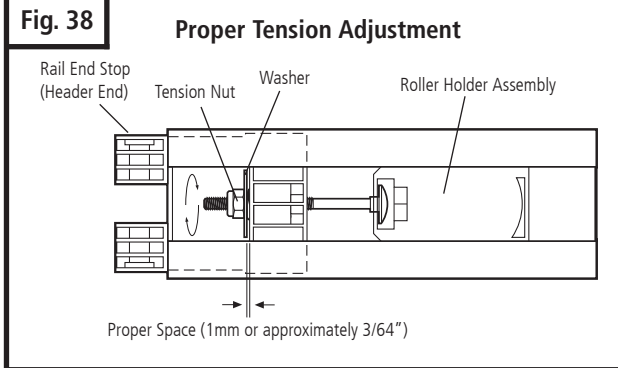

### TO SHORTEN CHAIN RAIL LENGTH:

- Loosen chain tension as much as possible.
- Remove screws from sprocket holder and rail end-stop.
- Slide chain and all rail parts out of rail from header end. See rail exploded view, Fig. 42 on p. 29, for disassembly details.
- Measure and cut off excess rail from header end by 1" increment only.
- Using rail end-stop as a guide, mark and drill two 3/16" holes on rail sides for rail end-stop screws.
- Disassemble connector to expose free ends of chain.
- Using the same measurement as the excess rail length, remove the same amount off chain links and chain straps from BOTH free ends of the chain (Fig. 40).
- Reassemble two piece connector and slide chain and all rail parts into rail from header end according to original assembly (Fig. 38 and Fig. 39).
- Tension chain properly (Fig. 38).
- Check rail for proper assembly and operation by manually moving trolley from end to end and back to position per Fig. 39, with trolley connected to chain.

## 7-4. ATTACH RAIL TO OPENER HEAD

### WARNING

**When fastening the rail to the opener, use only the screws provided. Use of any other screws may result in opener falling from ceiling and causing damage to persons or property in the garage.**

**NOTE:** Rail comes fully preassembled with straight door arm already attached.

- Unpack one-piece preassembled rail.
- Leave straight door arm taped inside rail for safe and convenient installation—it will be untaped and used later.
- Position door opener head with control panel facing front of garage. Rest opener head on cardboard or protective surface on floor so opener does not get scratched. Chassis side of opener (with motor shaft sticking out) facing up.
- Position rail onto opener chassis by lining up rail sprocket opening with motor head shaft (Fig. 15A). Make sure shaft engages teeth inside rail sprocket. Press rail down firmly onto shaft and opener chassis. **DO NOT HAMMER.**
- Position 2 "C" brackets over rail and onto chassis. Flanges on "C" brackets **MUST** fit into cutout area on chassis (Fig. 15B).
- Insert screws (6 x 14) through bracket holes and into chassis holes, and tighten screws firmly to hold rail to head (Fig. 15C).
- For sectional doors, proceed to step 7-5.

### ADDITIONAL STEP FOR ONE-PIECE DOORS ONLY:

**IMPORTANT NOTE:** For installation on One-Piece Doors only, the straight door arm that is factory installed onto the rail must be replaced by the curved door arm supplied as part of hardware in powerhead box. This must be done after attaching rail to powerhead, before moving to step 7-5.

- Turn rail and opener head over so that open channel in rail faces up.
- Untape straight door arm that is secured inside rail.
- Remove and save the two phillips head screws that are securing the door arm pin and straight door arm (Fig. 16).
- Lift arm and pin straight out of slot in trolley, and remove pin from straight door arm.
- Insert pin into short side of curved door arm as shown.
- Orient arm so that long side extends away from trolley.
- Carefully insert pin and door arm into slot in trolley. Push pin into slot with door arm so pin is fully seated into trolley slot. **IMPORTANT:** Pin must be straight and seated properly into recessed area in trolley. See Figs. 16A and 16B.
- Secure pin and curved arm with the two phillips screws which were removed from trolley—**DO NOT** use any other screws. Tighten screws firmly.
- Turn rail and powerhead over so that open channel in rail faces down. Now proceed to Step 7-5.

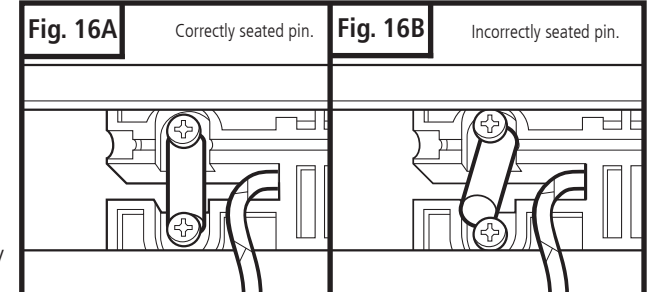
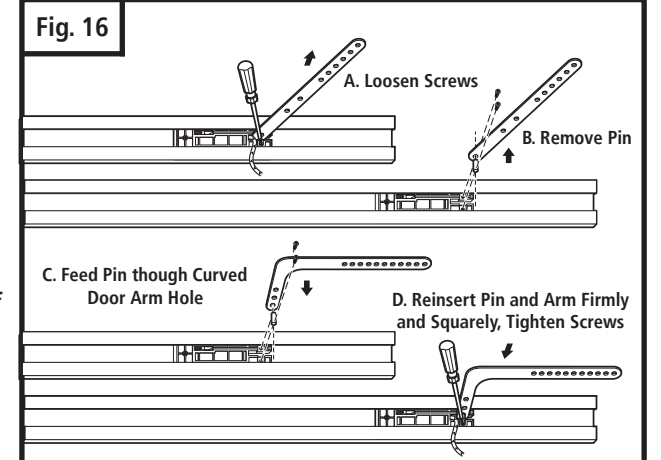
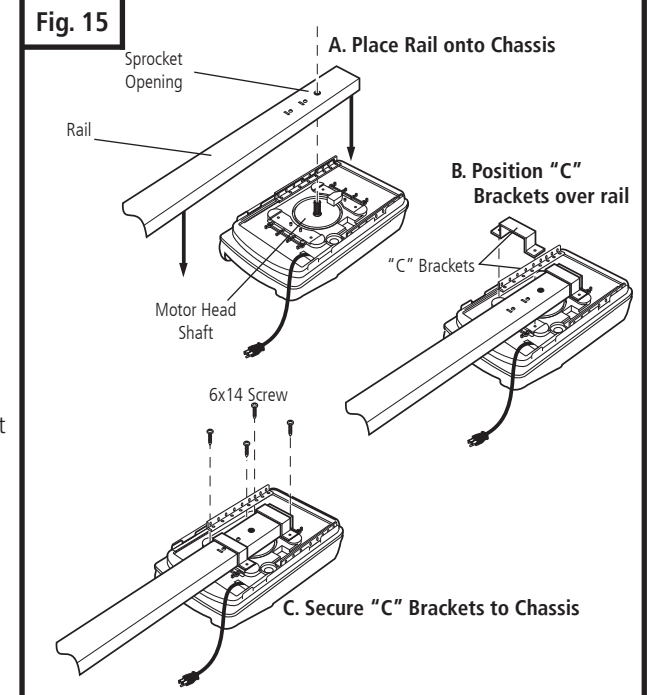

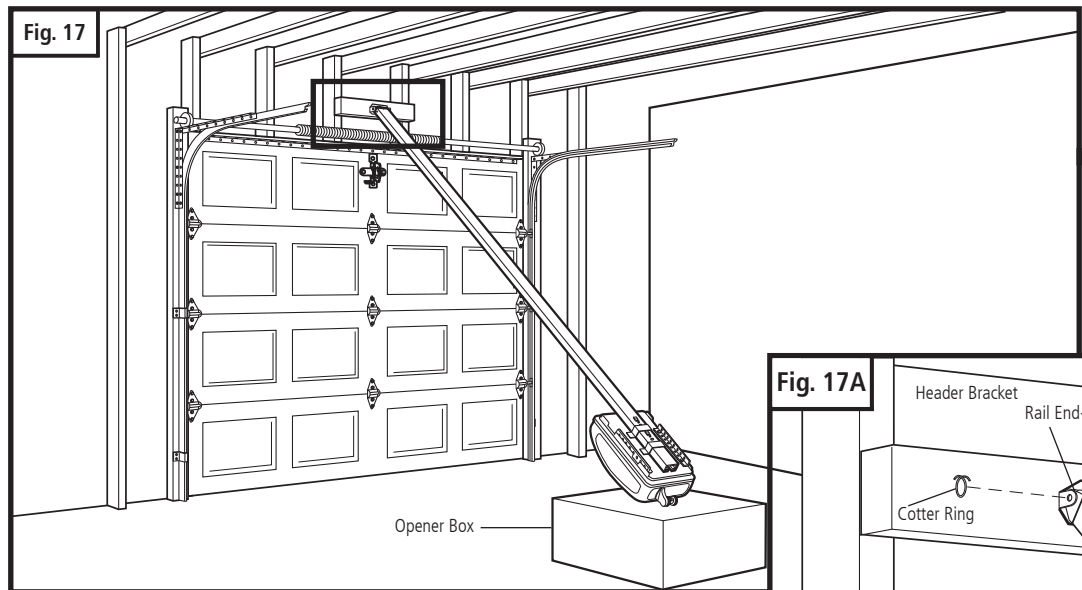

Fig. 17

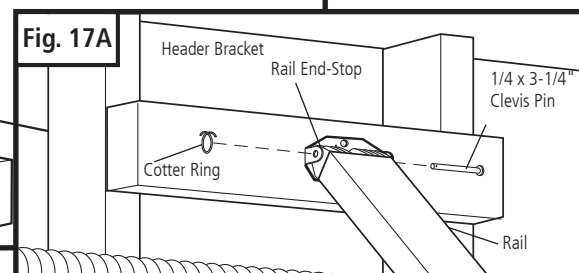

Fig. 17A

### 7-5. ATTACH RAIL TO HEADER BRACKET

- Support opener head slightly off the floor.
- Lift the opposite end of the rail up to the header bracket.
- Position rail end-stop within the openings in the header bracket. Insert header clevis pin ( 1/4" dia.) through header bracket and rail end-stop, then attach cotter ring to end of pin. (See Fig. 17A)

### 7-6. POSITION OPENER FOR MOUNTING

Once rail is attached to header bracket, support opener power head on ladder, or use the assistance of another person to support opener powerhead high enough so door can open without hitting the rail.

#### A. SECTIONAL DOORS AND ONE-PIECE DOORS WITH TRACK:

- Open garage door to fully opened position, and place 50x100mm board between the door and the rail. See Fig. 18.
- The board provides an easy method of ensuring the correct mounting height of the opener.

#### B. ONE-PIECE DOORS WITHOUT TRACK:

- Disconnect trolley by pulling down on emergency release knob. Move trolley toward opener head.
- Open door all the way so that it is parallel to the floor, or slightly tilted toward the front of the garage. **DOOR SHOULD NOT BE TILTED TOWARD THE BACK OF GARAGE.**
- Position opener so that top of opener head is level with top of opened door.
- To check for correct mounting height, temporarily position curved door arm as if connecting to door bracket. See Fig. 19. The long side of the arm should be parallel to the floor when door is fully opened. Raise or lower powerhead so that arm will be parallel to floor.
- Temporarily support head at this height, and prepare to mount the opener to ceiling.

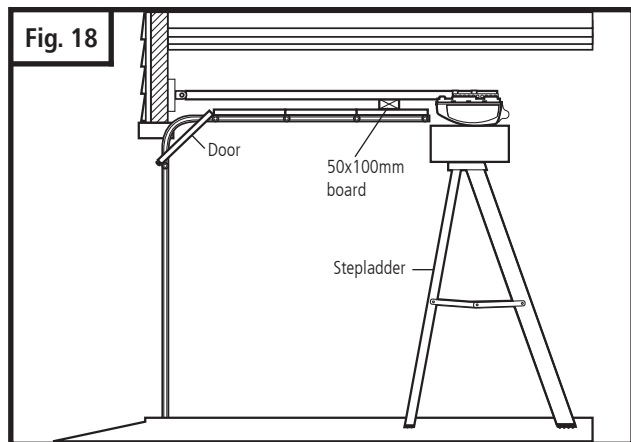

Fig. 18

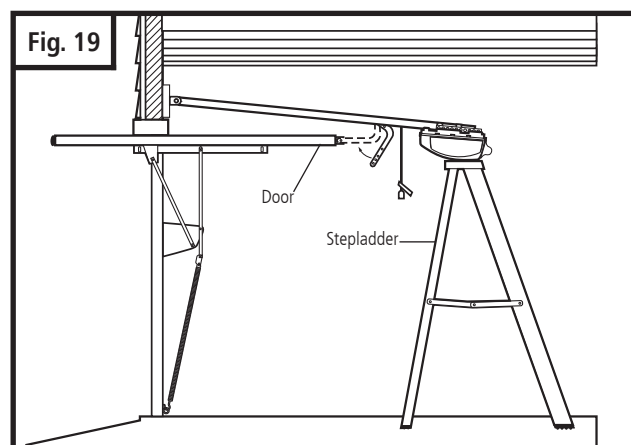

Fig. 19

## 10. OPERATION OF YOUR OPENER

Your opener can be activated via any of the following, depending on which accessories your opener system has:

- Remote Control Transmitter
- Wall Control Panel
- Keyless Entry (optional accessory)

#### REMOTE CONTROL TRANSMITTER:

- To open or close garage door, press and hold button (Transmitter has an indicator light that will illuminate). See Fig. 37A. When garage door begins to move, release button.
- To stop garage door during travel, press and hold button until door stops, then release button.
- To resume garage door travel after stopping, press button again. Door begins to move in the opposite direction.

#### WALL CONTROL PANEL:

- The Door Pushbutton will light when Wall Control properly connected (if it does not light up, review section 7-11. "Install Wall Control" on page 13). To open or close garage door, press and hold Illuminated Door Pushbutton. See Fig. 37B. When garage door begins to move, release button.
- To stop garage door during travel, press and hold button until door stops, then release button.
- To resume garage door travel after stopping it, press button again. Door begins to move in the opposite direction.
- The Light On / Off button can be used to turn lights on or off. When using the light On / Off button, the automatic timer is ignored, and the lights will remain on until the button is pressed again, or until the opener is activated and the automatic timer begins again.
- The Lock/Vacation button can be used to lock out all remote control transmitters. The door can still be activated by wall control panel or keyless entry system. Press and hold Lock/Vacation button for 2-3 seconds. Release button. Illuminated Door Pushbutton will flash continuously while lock mode is active. To unlock opener, press and hold Lock/Vacation button for 2-3 seconds.

## 11. TEST SAFETY REVERSAL

The safety reversal function of your opener is an extremely important feature of your opener. Testing this function ensures the correct operation of your opener and door.

The reversal system test should be performed:

- Once per month.
  - Anytime the travel or force limits are reset or changed.
- Once the adjustments have been set and the door has been run up and down twice to "learn" the new settings, you must test the reversal system for proper operation.
- Place a 40mm (1-1/2") high rigid object (or a 2x4 board laid flat) on the floor directly in the path of the door.
  - Start the door in the downward direction and watch what happens.

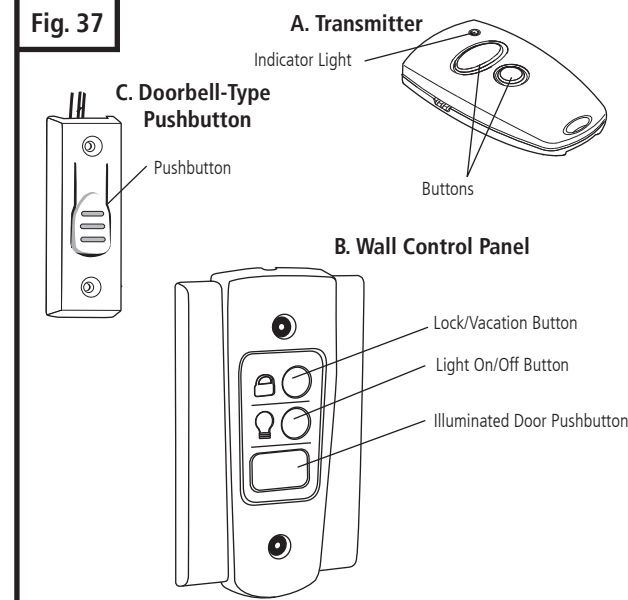

Fig. 37

#### DOORBELL-TYPE PUSHBUTTON:

- To open or close garage door, press and hold Pushbutton. See Fig. 37C. When garage door begins to move, release button.
- To stop garage door during travel, press and hold button until door stops, then release button.
- To resume garage door travel after stopping it, press and hold button until door begins to move, then release button.

#### OPENER LIGHTS:

- Lights will come on whenever opener is activated. Lights will stay on for 4 minutes and 15 seconds, or until the Light On/Off button on the wall control panel is pressed, whichever is sooner.
- Lights can be turned on and off manually as described under operation of wall control panel.
- Lights will flash when the opener senses an obstruction either detected by the internal safety system or the photo eye. To stop lights from flashing, remove obstruction and operate door normally.



## 9. TRANSMITTERS

### TRANSMITTERS (Fig. 31):

A family of state-of-the-art transmitters, each transmitter is custom encoded with installed battery. Offered in two styles to suit your personal preference.

- Mini (2-or 4-channel)
- Micro (3-channel) with keyring attachment.

### TRANSMITTER MOUNTING:

The transmitters can be conveniently mounted inside your car using the visor clip or on the wall using the mounting plate.

#### Visor Clip (Fig. 32)

- Snap visor clip into transmitter.
- Affix assembly to visor.

**NOTE:** If you do not need the visor clip, install the visor compartment cover.

#### Mounting Plate (Fig. 33)

- Secure the mounting plate to area of preference using screw and anchor.
- Snap the visor compartment cover.
- Slide the transmitter into the mounting plate, which will hold it firmly in place.

### MULTIPLE TRANSMITTERS (Fig. 34):

Each transmitter comes factory programmed with random codes. 2-channel transmitters have 2 different random codes, one per button, 3-channel transmitters have 3 different random codes and 4-channel transmitters have 4 different random codes, one per button. Transmitters that are purchased separately as accessories have random codes that must be changed in order to match the code of the "active" transmitter, which you are already using. Below are instructions for transferring an active code from a button on one transmitter to a button of your choice on another transmitter.

- Connect the transmitter with active code to the new transmitter using the programming connector. (Fig 34)
- Press and hold the selected channel button on the transmitter with the active code.
- Press and hold the respective channel button on the new transmitter. The light in the transmitter initially starts blinking and then illuminates continuously after 1-2 sec. Code transfer is completed.

- Programming connector can be removed and both transmitters can now be used to operate the same opener.

**NOTE:** For multi-button transmitters, be sure to carry out this procedure for all the buttons you desire to use.

### CHANGING THE CODE (Fig. 35):

The transmitter factory preset code can be changed as follows:

- Insert the programming connector into transmitter terminal.
- Short one of the outer pins of the programming connector with the middle pin.
- Press and hold the respective channel button. The light will blink rapidly for approximately 5 sec. Release the button after the light illuminates continuously. Code will change in approximately 2 seconds.
- Remove the programming connector.

**NOTE:** For multi-button transmitters, be sure to carry out this procedure for all the buttons you desire to use.

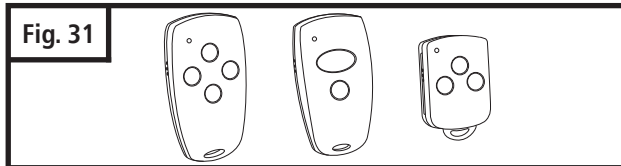

FCC Certified: This device complies with Part 15 of the FCC rules. Operation is subject to the following two conditions: (1) this device may not cause harmful interference, and (2) this device must accept any interference received, including interference that may cause undesired operation. Changes or modifications not expressly approved by the party responsible for compliance could void the user's authority to operate the equipment.

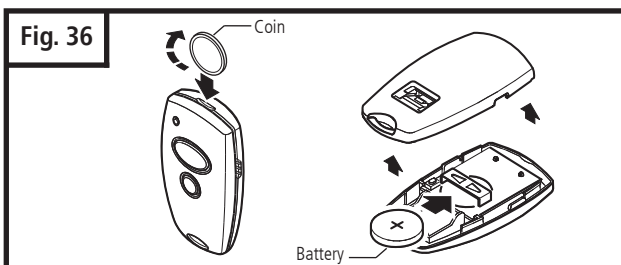
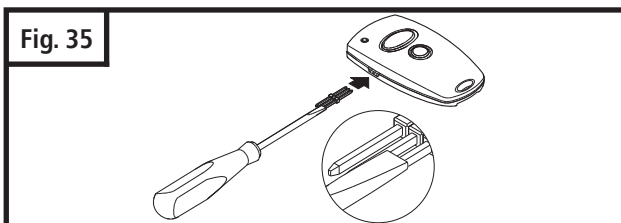
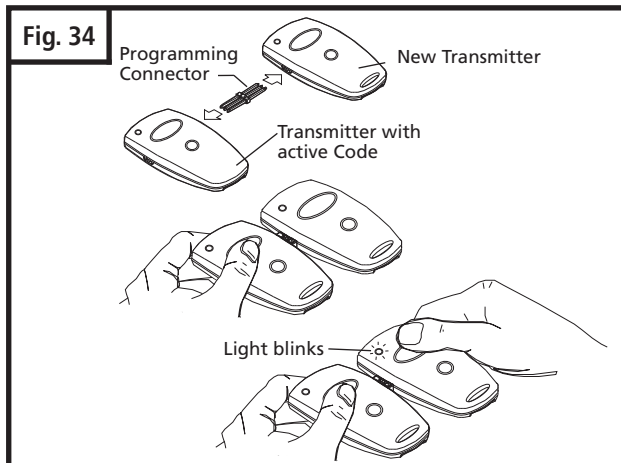
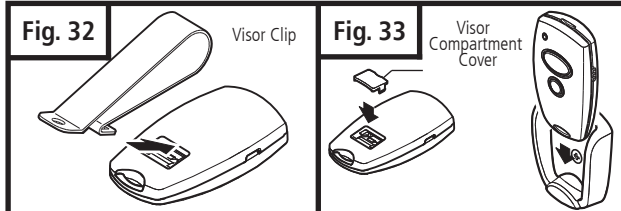

### BATTERY REPLACEMENT (Fig. 36):

- Open the transmitter by using small coin.
- Insert a 3V battery (type CR2032) as shown.
- Close the transmitter.

**NOTE:** Replace batteries with same type only.

## 7-7. MOUNT OPENER TO CEILING

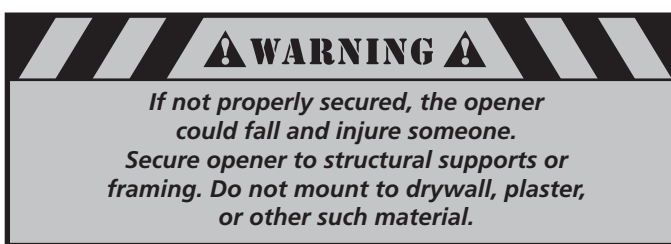

- Position opener head so that rail is lined up with center line of open door.
- Line up hanger brackets (not provided) with ceiling joists or framing to locate where brackets are to be fastened. See Fig. 20.
- Mark location for 5/16" lag screws (not provided), and drill two 3/16" pilot holes.
- Fasten hanger brackets to joists using lag screws.
- If garage framing supports are not visible, attach a length of perforated angle or a 50x100mm (2x4) board to the ceiling, securing it to the hidden joists with lag screws long enough to fasten firmly to garage framing (extra hardware items not provided). Then, attach one end of hanger brackets to the angle or board mounted to ceiling. Attach other end of hanger brackets to opener's perforated angles. See Fig. 21 for an alternate mounting methods.
- Once opener is securely fastened in position, remove wood blocks and temporary supports and lower door. Check door for proper operation and clearance by manually moving door to full open and closed position. If door hits rail at any point, raise opener head slightly higher and re-mount in position.

**NOTE:** To provide additional support for rails 4m (13') length and longer, use optional support bracket. (Accessories p.32)

- Measure the rail's overall span. Bracket is located on 1/3rd of the overall rail span from the door header bracket end. See Fig. 22
- Place support bracket over rail (close side) on a diagonal. Make sure support securement clamps clear rail sides.
- Secure bracket onto rail by twisting support bracket as indicated in Fig. 22A.
- Attach mounting strap (not provided) to support bracket and secure by fastening it to the ceiling.

## 7-8. CONNECT ARM TO DOOR AND TROLLEY

- Make sure door is fully closed.
- Remove tape from rail holding straight door arm (sectional door only) and allow door arm to hang freely.
- Pull the manual release cord on the trolley to disconnect trolley from chain or belt connector. Slide trolley to position it about 100mm (4") away from the door.

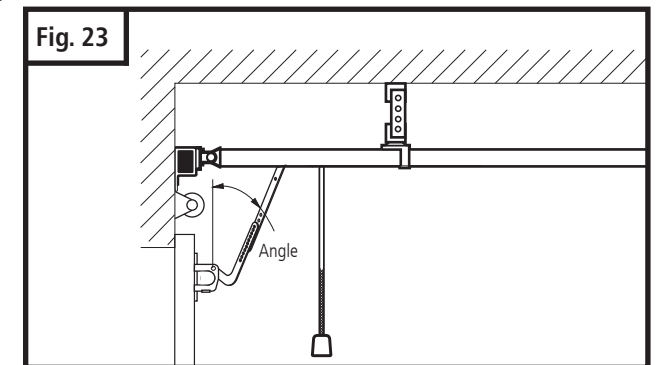
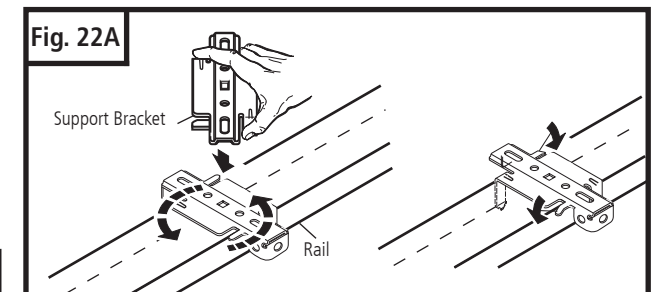
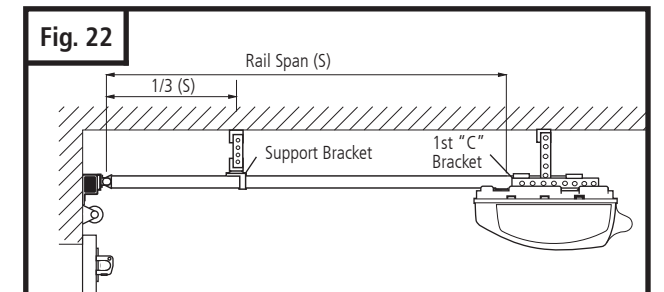
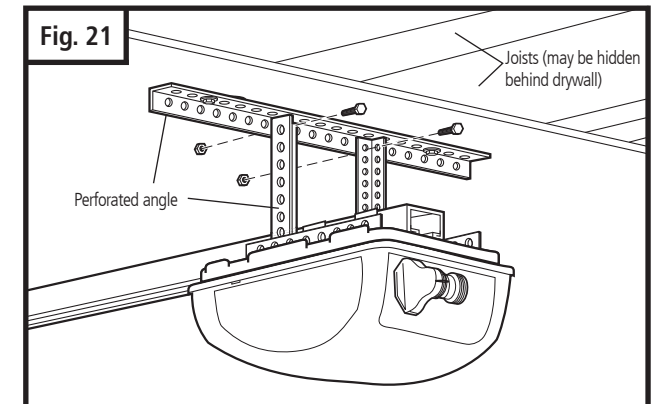
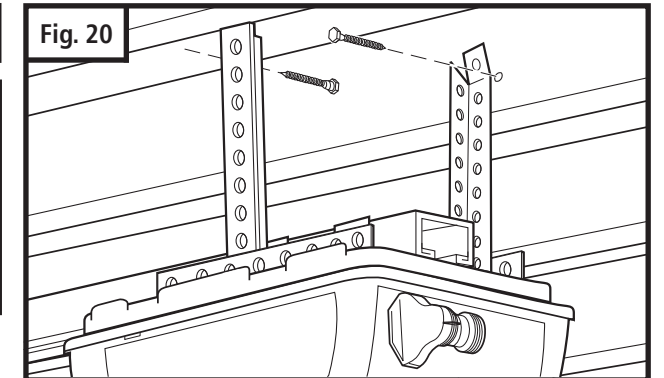

## 7-8. CONNECT ARM TO DOOR AND TROLLEY (cont'd)

### A. SECTIONAL DOORS:

- Position curved door arm into door bracket channel so that short end of arm will be attached to door bracket. See Fig. 24. Curved door arm should be attached roughly at the same height as the top rollers of the door.
- Align curved door arm and bracket holes, then insert clevis pin through holes. Attach cotter ring to hold pin in place.
- Position straight arm and curved arm to form an angle with the door (Fig. 24) and at least two sets of holes line up. Select two overlapping holes as far apart as possible and secure arms together with hex bolts (5/16-18) and lock nuts.

### B. ALL ONE-PIECE DOORS:

- Curved door arm should already be attached to trolley in place of straight door arm. See Fig. 16, p. 9.
- Position free end of curved arm into door bracket slot. Align curved door arm and bracket holes, then insert clevis pin (5/16" dia.) through holes. Attach cotter ring to pin to hold in place. See Fig. 25.

### C. SECTIONAL AND ONE-PIECE DOORS:

- After connecting appropriate door arm, ensure trolley is disengaged. Check for proper door operation by manually lifting then lowering to fully opened and closed positions.
- Readjust door arm if needed.

**PULL DOWN ON RELEASE KNOB TO LOCK TROLLEY, THEN MOVE DOOR MANUALLY UNTIL TROLLEY LOCKS WITH CHAIN OR BELT CONNECTOR.**

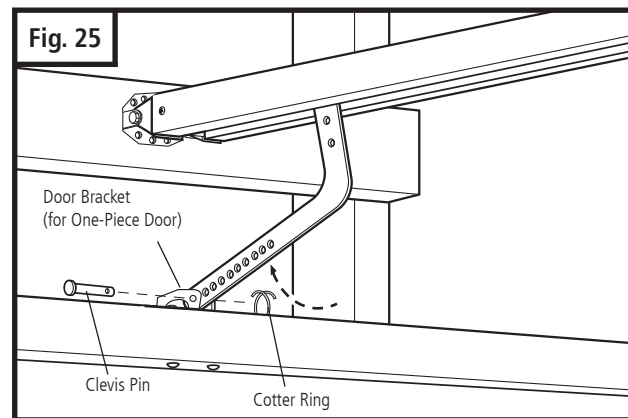
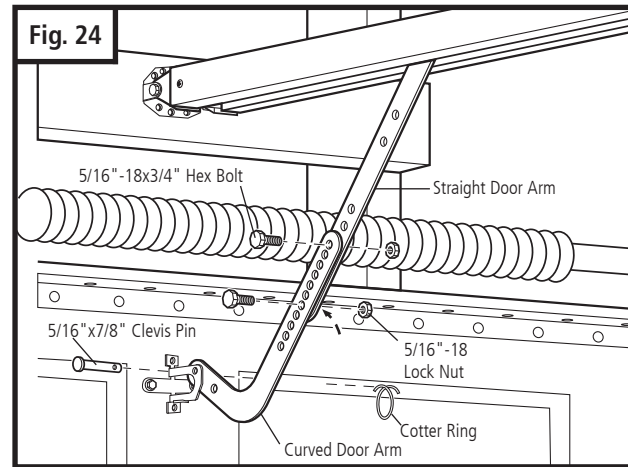

## 7-9. CHECK EMERGENCY RELEASE

### WARNING

**Use extreme care when pulling release knob. DO NOT use knob to pull door open or closed. Except for emergency situations, use knob only when door is closed.**

The emergency release cord with red knob, which is already attached to the trolley, are extremely important parts of the opener system Fig. 26. Pulling the release cord disengages the door from the opener. This allows the door to be moved manually up and down independent of the opener motor.

**If the door is in the open position, use extreme care when using the release.**

Use emergency release to disconnect the door if the power is out. It should also be used if for some unforeseen reason the door strikes a person or object during its travel and does not automatically reverse off the obstruction.

**To release door - pull firmly down on red knob. (Fig. 26)**

Prior to re-engaging door, ensure that all obstructions are removed and door is operating properly manually. Before re-engaging trolley with a chain or belt connector, pull down knob again, then release. The red catch will stop in the "lock" position and will open indicator window (see Fig. 26A). Now the door can be reconnected by moving it manually and bringing it into position when the connector is inside of the trolley.

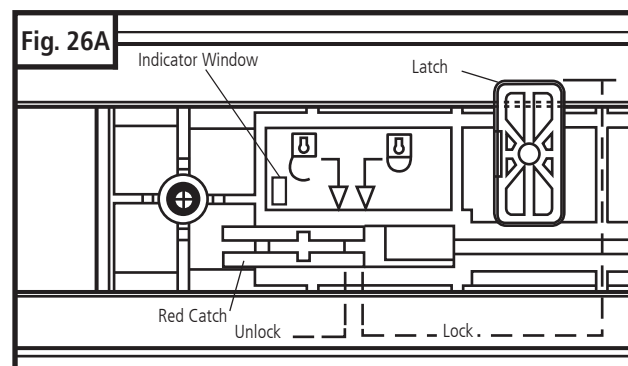
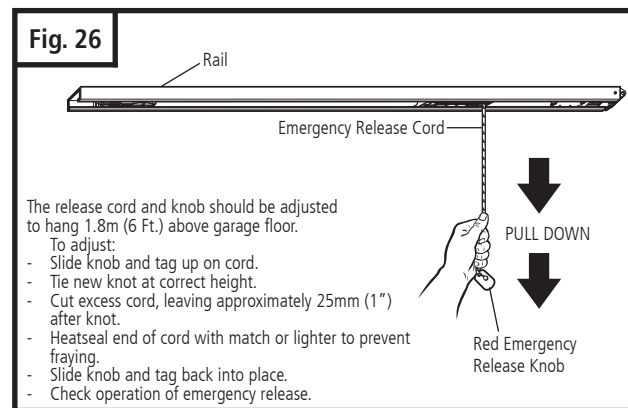

## Level 4 Menu 3

### SET EXTERNAL SIGNAL LIGHTS ( )

- LED blinks and all others are illuminated.
- Use or to set the signal light function

LED blinks: external signal will be illuminated  
LED illuminated: external signal will blink

external signal will be illuminated      external signal will blink

- Press to store setting in memory and go to **Menu 4**.

## Level 4 Menu 4

### SET OPENER LIGHT FUNCTION ( )

- LED blinks and all others are illuminated.
- Use or to set the signal light function

LED blinks: opener light will be illuminated during warning phase  
LED illuminated: opener light will blink during warning phase

opener light will be illuminated during warning phase      opener light will blink during warning phase

- Press to store setting in memory and go to **Menu 5**.

## Level 4 Menu 5

### SET EXTERNAL RELAY ALARM FUNCTION

- LED blinks and all others are illuminated.
- Use or to set the signal light function

LED blinks: external light will be illuminated during lighting phase  
LED illuminated: external light relay 30 seconds alarm signal on actuation of the back drive protection system

External light will be illuminated during lighting phase      External relay 30 seconds alarm signal on actuation of the back drive protection system

- Press to store and to finish setting up the external light.

The LED will automatically turn off starting at LED and ending at LED .

Opener is now in operational (normal) mode recognizable by illuminated LED and possible LED (door fully open) or LED (door fully closed).









## LEVEL 4 . SECURITY / SAFETY CONTROLS





















### MENU OVERVIEW

1. Set light(s) "on" time
2. Set timed security cut out
3. Set external signal lights
4. Set opener lighting
5. Set external relay alarm function

### Level 4 Menu 1

#### SET LIGHT(S) "ON" TIME ( )



1. Press  for 10 seconds until LED  flashed rapidly and all others are illuminated. Still hold the P button and press the  button until LED  blinks and all others are illuminated.
2. LED  blinks and all others are illuminated.
3. Use  or  to set desired time  
 minimum time: 90 seconds  
 maximum time: 240 seconds





















																				
90	95	100	110	120	130	140	150	160	170	180	190	200	210	220	240					
seconds	seconds	seconds	seconds	seconds	seconds	seconds	seconds	seconds	seconds	seconds	seconds	seconds	seconds	seconds	seconds	seconds	seconds	seconds	seconds	seconds

3. Press  to store setting in memory and go to **Menu 2**.

### Level 4 Menu 2

#### SET CUT OUT (MAX. TRAVEL TIME) TIMER

1. LED  blinks and all others are illuminated.
3. Use  or  to change value  
 minimum time: 30 seconds  
 maximum time: 240 seconds

																				
30	40	50	55	65	80	100	120	140	160	180	190	200	210	220	240					
seconds	seconds	seconds	seconds	seconds	seconds	seconds	seconds	seconds	seconds	seconds	seconds	seconds	seconds	seconds	seconds	seconds	seconds	seconds	seconds	seconds

3. Press  to store setting in memory and go to **Menu 3**.

## 7-10. INSTALL WALL CONTROL PANEL

The control panel must be mounted inside the garage within sight of the garage door, clear of all moving garage door parts or any associated parts - and at least 1.3m (5ft) above the floor to prevent the use of these controls by children. The device should only be used when the door is in clear sight of the user and the door area is free of people or any obstructions.

- Attach 2-conductor wire to the screw terminal on back of control panel. See Fig. 27 (Back). White wire attaches to terminal #3 screw, white wire with color stripes attaches to terminal #4 screw.
- Position wall control panel onto wall in desired location.
- Mark hole location on wall.
- Drill 1/16" pilot holes into wall.
- Insert and tighten screws to secure control panel to wall.
- Make sure wiring is routed out from behind control through one of the cutouts to avoid pinching the wires.

*If mounting to drywall instead of wood, drill 3/16" pilot holes and use anchors provided.*

*If mounting to electrical box that is prewired for this purpose, mount directly to box with proper screws provided.*

- Run wires from wall control panel along wall and ceiling to opener powerhead. Use the staples that are provided to secure wiring to wall, joists and ceiling. Do not pinch wiring. Drive staples with only enough force to hold wiring in place.
- Insert white single wire from wall control into terminal #3 and single color striped wire into terminal #4. (Fig. 29)

**NOTE:** *If wires are difficult to insert, a screwdriver may be used to depress the terminal "tab" while inserting the wires. To remove wires, depress tab again and pull wires out.*

**Multiple wall controls may be installed in parallel with wires connected to terminals #3 and #4.**

- Detach right side panel from one of the wall controls. (Fig. 27)
- Attach wiring to back of both wall controls (White wires to terminal #3 screws, wires with stripes to terminal #4 screws.)
- Follow the same steps as above to mount additional wall control panels and wire connections.

#### Doorbell-Type Pushbutton

Follow the same steps as above with one exception, mark both mounting holes at same time, then drill and secure unit to wall (in the case of the doorbell-type Pushbutton, it does not matter which wire attaches to which terminal. See Fig. 28).

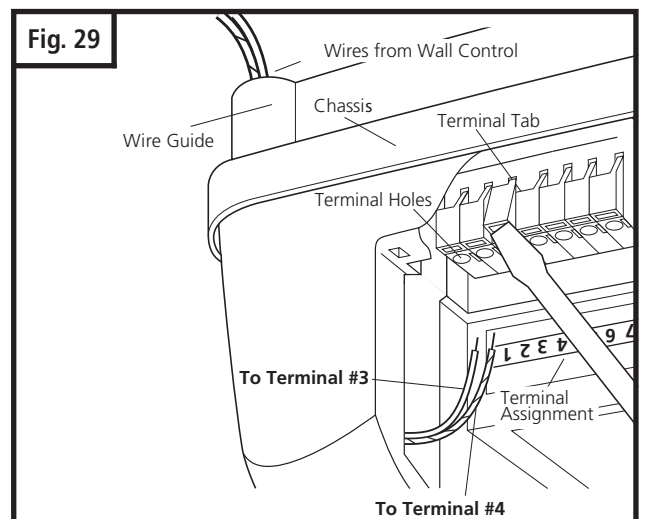
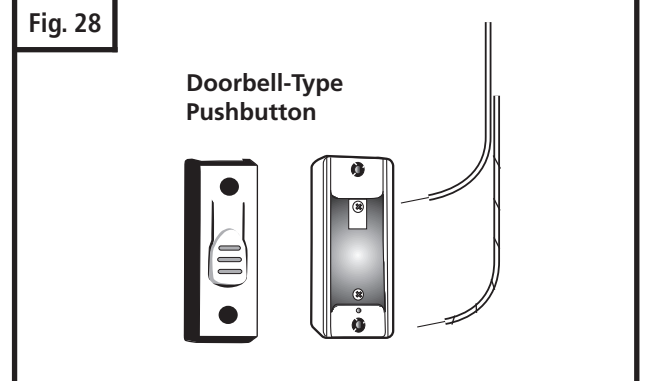
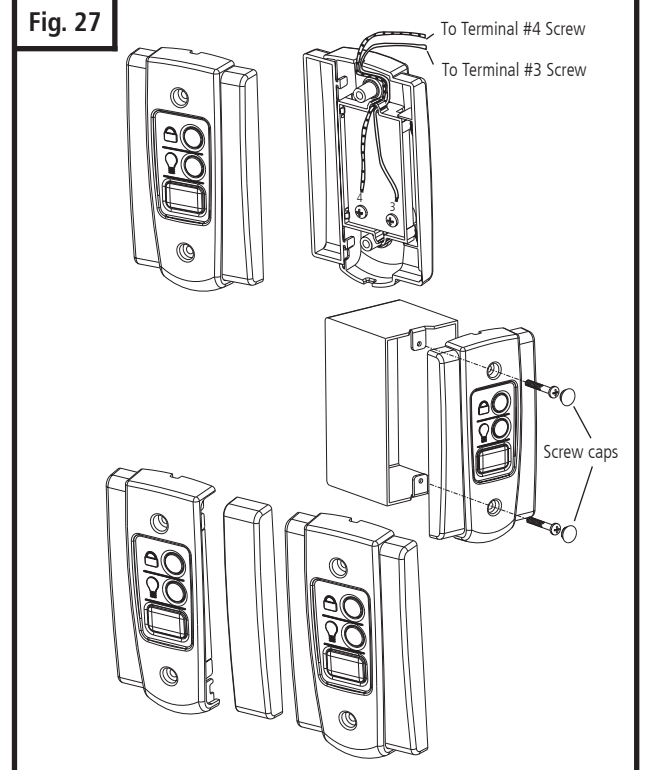

## 7-11. INSTALL LIGHT BULBS AND LENSES

### CAUTION

To prevent possible **OVERHEATING** of the end panel or light socket:

- Use **ONLY** standard incandescent light bulb(s).
- **DO NOT** use a bulb with a rating higher than 60 Watts (W). A stronger or larger bulb may result in fire or damage to the opener.

To prevent possible radio frequency (RF) signal interference:

- Do not use compact fluorescent lighting (CFL).

- Install a maximum 60 W incandescent bulb (not provided) into lamp socket(s).
- Install lamp lens(es). Two lenses for a EX-2007 model, one lens for a EX-2005 model.
- Line up lamp lens tabs with slots in housing and snap securely into place. Repeat same procedure with second lamp lens on the opposite side, if you have an EX-2007 power head.
- Line up lamp lens tabs with corresponding slots in chassis. Snap lens onto chassis for EX-2005 model.
- To remove lamp lens, pull lamp lens to unsnap from housing and chassis.

Fig. 30

**NOTE:** Use only standard light bulbs. The use of short neck or speciality light bulbs may overheat the endpanel or light socket.

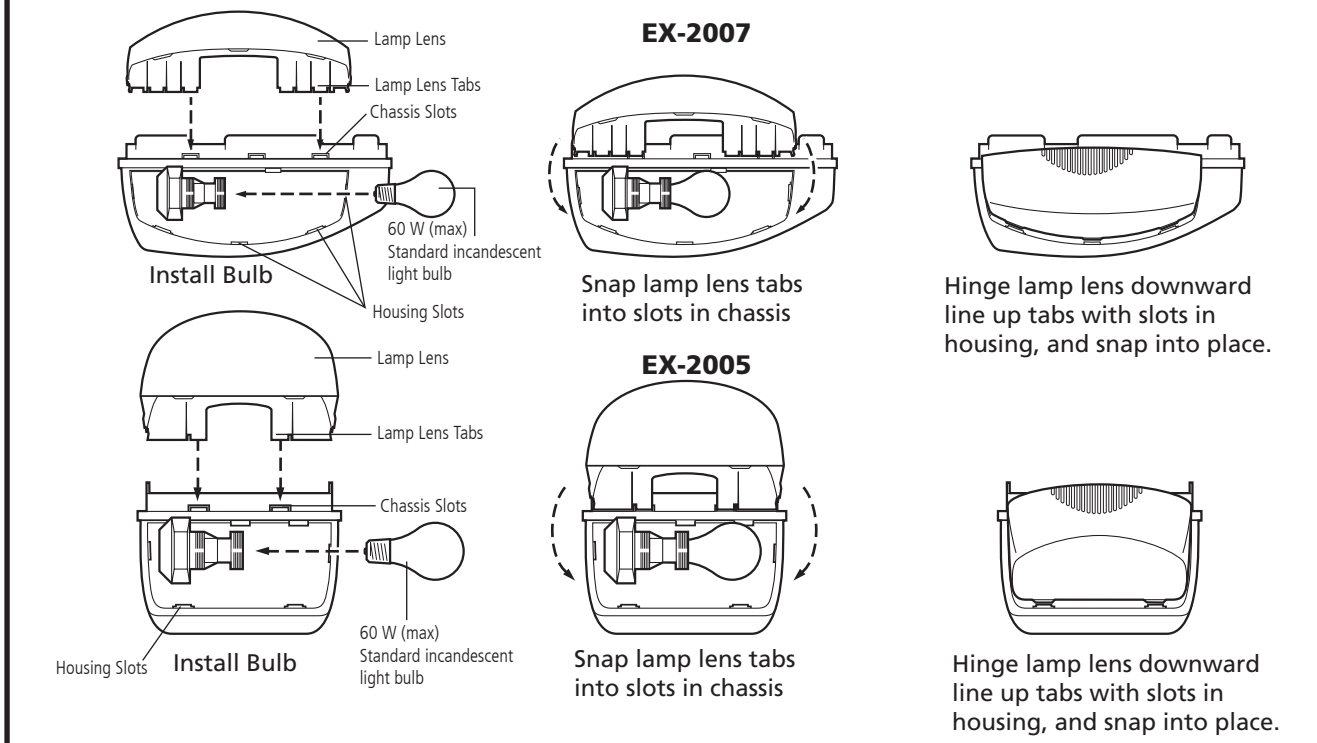

## 7-12. CONNECT TO POWER

For 120V application to reduce the risk of electric shock, your opener is provided with an insulated power cord with a 3-prong grounding plug. The cord must be connected to a standard grounding outlet. If there is no outlet available at the location, you must have a qualified electrician install an approved grounded outlet in this area.

- Plug the opener into a properly grounded outlet.
- An indicator light (LED #8) on the opener control panel will turn on showing that the power is "On" and the opener is ready to set the adjustments.
- DO NOT operate or run the opener at this time.

### WARNING

To prevent electrocution or fire, installation and wiring must be done in accordance with local electrical and building codes. DO NOT use an extension cord. DO NOT use a 3 to 2 plug adapter. DO NOT modify or cut off the grounding pin on the plug.

### WARNING

To prevent electrocution, disconnect the opener from power and turn off power at circuit breaker for the circuit you will be using to connect to the opener.

## Level 3 Menu 3

### SET START-UP WARNING

1. Make sure LED is blinking and all others are illuminated.
3. Use or to change the start-up warning phase
  - minimum phase: 0 seconds
  - maximum phase: 7 seconds

0 seconds	1 seconds	2 seconds	3 seconds	4 seconds	5 seconds	6 seconds	7 seconds

3. Press to store setting in memory and go to **Menu 4**.

## Level 3 Menu 4

### SET EARLY CLOSING AFTER PASSING THE DRIVEWAY PHOTO EYE SENSORS

1. Make sure LED is blinking and all others are illuminated.
2. Use or to choose the required setting
  - LED blinking: Door will close after set door open period
  - LED illuminated: Door will close immediately after driving through the Beam Break

Door will close after set door open period	Door will close immediately after driving through the Photo eye sensors

3. Press to store and to finish setting up the automatic closing feature.

The LEDs will automatically turn off starting at LED and ending at LED .  
Opener is now in operational (normal) mode recognizable by illuminated LED and possible LED (door fully open) or LED (door fully closed).

### LEVEL 3. AUTOMATIC CLOSING



**Attention:**  
When using this feature a photo eye safety system must be connected and programmed in accordance with Level 2 Menu 1.

#### Menu Overview:

1. Set door open period
2. Set warning phase time
3. Set start-up warning
4. Set early closing after passing the driveway photo eye sensors

#### To Set Up Automatic Closing:

##### Level 3 Menu 1

###### SET DOOR OPEN PERIOD (AUTOMATIC TIMER) Opener is in normal operating mode.

1. Press for 10 seconds until LED flashes rapidly and all others are illuminated.  
Still hold the P button and press the button until LED blinks and all others are illuminated.
2. Release . LED blinks and all others are illuminated.
3. Use and to change time.  
minimum time: 5 seconds  
miximum time: 255 seconds

timer	5	10	15	20	25	30	35	40	50	80	100	120	150	180	255
deactivated	seconds	seconds	seconds	seconds	seconds	seconds	seconds	seconds	seconds	seconds	seconds	seconds	seconds	seconds	seconds

3. Press to store setting in memory and go to **Menu 2**.

##### Level 3 Menu 2

###### SET WARNING PHASE TIME

After having programmed the automatic timer function LED will blink.

1. Make sure LED is blinking and all others are illuminated.
2. Use or to change value  
minimum time: 2 seconds  
maximum time: 70 seconds

2	5	10	15	20	25	30	35	40	45	50	55	60	65	70
deactivated	seconds	seconds	seconds	seconds	seconds	seconds	seconds	seconds	seconds	seconds	seconds	seconds	seconds	seconds

3. Press to store setting in memory and go to **Menu 3**.

### 8. OPENER PROGRAMMING



**Attention:**  
The opener has four (4) programming levels.  
For normal operation of the opener you only program the “open”, “closed” positions and the remote control in the Basic settings.  
Changes in the extended programming level may only be carried out by specialist.

#### 8-1. PROGRAMMING OVERVIEW

Menu	Basic Settings		
Menu 1	Programming ‘door open position’		
Menu 2	Programming ‘door closed position’		
Menu 3	Programming of remote control (transmitter)		

LEVEL 2	Advanced Settings	Explanation	Factory Settings
Menu 1	Add beam break (photo eye system)	Setting whether the opener runs with or without photo eye sensors	Without photo eye system
Menu 2	Set maximum OPENING force	The sensitivity of power limit can be set in steps from 1 – 16	Step 6/16
Menu 3	Set maximum CLOSING force	The sensitivity of power limit can be set in steps from 1 – 16	Step 6/16
Menu 4	Set ‘offset’ learned power limit (sensitivity)	The sensitivity of power limit can be set in steps from 1 – 15	Step 7/15
Menu 5	Set ‘opener speed’	Travel rate may be adjusted by changing the opener speed	Step 16 (max. speed)

LEVEL 3	Advanced Settings	Explanation	Factory Settings
Menu 1	Set door open period	The time when door remains open until it closes automatically. Note: This function only works when photo eye system is connected and programmed.	deactivated
Menu 2	Set warning phase time	Setting where a signal light will flash before the door closes	deactivated
Menu 3	Set start-up warning phase	Setting where a signal light will flash before the door starts to move with delayed door start	warning before start deactivated
Menu 4	Set early closing after passing the driveway photo eye sensors	Setting where the door will close after passing the photo eye sensors and before the set time has expired	none

LEVEL 4	Advanced Settings	Explanation	Factory Settings
Menu 1	Set light(s) “On” time	The lighting time of the operator light(s) can be programmed	180 sec.
Menu 2	Set timed security cut out	Programs the maximum door travel time	80 sec.
Menu 3	Set external signal light	The signal light can be set to flash or permanent light	none
Menu 4	Set opener light function	The operator light can flash at automatic time function	none
Menu 5	Set external relay alarm function	The electric push open security device can be programmed as alarm output signal	none

## 8-2. CONTROL PANEL

The control panel is located under the control panel cover. Open the control panel by slightly pulling on the cover cutout, then allowing the cover to drop open. The hinges enable the cover to remain in place while you set the adjustments. On control panel you will find 3 buttons labeled "P", "+", and "-" which allows you to set all the adjustments of your opener and a circular LED display with 8 numbered icons which shows useful status information regarding the opener and its function.

### Light icons:

- External beam break (photo eye safety system)
- Lights up when door is in fully opened position
- Automatic timer
- Lights up when door is in fully closed position
- Briefly lights up when door passes reference point
- Flashes when a system fault is detected by opener. See section 18 "Troubleshooting" on p.34 for more information
- Lights up when opener is receiving a signal from wall control or pushbutton  
 Flashes rapidly when opener is receiving a signal from remote transmitter or keyless entry system
- Lights up when power is "on"

### Adjustment Buttons:

- Button "Close" or "Decrease"
- Button "Open" or "Increase"
- Programming button

LEGEND		
LED off	i.e.	
LED illuminated	i.e.	
LED blinking	i.e.	
LED rapid blinking	i.e.	
Button pressed		or  or
Operator light bulb	on:	
	off:	
External Lights	on:	
	off:	

Default settings: i.e.

## Level 2 Menu 3

### SET MAXIMUM CLOSING FORCE AND

- LED and LED blink and all others are illuminated.
- By pressing or set the desired maximum closing force. Each illuminated LED represents 1/16 of the maximum total force.

1/16	2/16	3/16	4/16	5/16	6/16	7/16	8/16	9/16	10/16	11/16	12/16	13/16	14/16	15/16	16/16
------	------	------	------	------	------	------	------	------	-------	-------	-------	-------	-------	-------	-------

- Once maximum closing force is set press to store setting in memory and go to **Menu 4**.



**Attention:**  
Set closing force as sensitive as possible (max. 150 N at closing edge)

## Level 2 Menu 4

### SET OFFSET AUTOMATIC LEARNED POWER LIMIT

- LED blinks and all others are illuminated.
- Use or to change offset in increments of 1/16 of the maximum.  
minimum offset: 1/15  
maximum offset: 15/15

1/15	2/15	3/15	4/15	5/15	6/15	7/15	8/15	9/15	10/15	11/15	12/15	13/15	14/15	15/15
deactivated														

- Press to store setting in memory and go to **Menu 5**.

## Level 2 Menu 5

### SET "OPENER SPEED"

- LED blinks and all others are illuminated.
- Use or to change the opener speed in steps of 7/16 to 16/16 (factory settings).  
minimum speed: 7/16  
maximum speed: 16/16

7/16	8/16	9/16	10/16	11/16	12/16	13/16	14/16	15/16	16/16
------	------	------	-------	-------	-------	-------	-------	-------	-------

- Press to store and to finish setting up the opener speed.  
The LEDs will automatically turn off starting at LED and ending at LED .  
Opener is now in operational (normal) mode recognizable by illuminated LED and possible LED (door fully open) or LED (door fully closed).



## LEVEL 2. ADVANCED SETTINGS

### Menu Overview

1. Add beam break (photo eye safety system)
2. Set maximum OPENING force
3. Set maximum CLOSING force
4. Set offset learned power limit (sensitivity)
5. Set "opener speed"



#### Attention:

The automatic cut out is set automatically. Only change it if necessary! Set the automatic cut out as sensitive as possible, according to EN 12445 and EN 12453

#### Advice:

The setting of the automatic cut out corresponds to the maximum power of the operator. At the first travel to OPEN or CLOSE direction after 'POWER ON' the automatic cut out is effective according to the adjustment. For further travels the self-learned power, that is more sensitive, is effective. The automatic cut out is still the upper limit of power.







### Set up Advanced Settings:

#### Level 2 Menu 1

##### ADD BEAM BREAK \*

\*Photo eye safety system is an optional accessory.





Opener is in normal operating mode with not activated Beam break feature.

































1. Press and hold  10 seconds until LED  flashes rapidly and all others are illuminated.
2. Release . LED  blinks and all others are illuminated.
3. To activate Photo eye feature press  twice until LED  illuminated.
4. Press  to store settings and to go to **Menu 2**.

Note: To deactivate Photo eye follow the same procedure except press  until LED  blinks rapidly.

#### Level 2 Menu 2

##### SET MAXIMUM OPENING FORCE AND

1. LED  and LED  blink and all others are illuminated.
2. By pressing  or  set the desired maximum lifting force.  
Each illuminated LED represents 1/16 of the maximum total force.

 	 	 	 	 	 	 	 	 	 	 	 	 	 	 	 
1/16	2/16	3/16	4/16	5/16	6/16	7/16	8/16	9/16	10/16	11/16	12/16	13/16	14/16	15/16	16/16

3. Once maximum opening force is set press  to store setting in memory and go to **Menu 3**.



#### Attention:

Set opening force as sensitive as possible (max. 150 N at closing edge)

## 8-3. IMPORTANT INFORMATION



#### Attention:

Before you start opener programming, make sure trolley is connected to chain or belt and door arm is attached to door.



- The door is not yet closed completely
- If there is a beam break (photo eye safety system) required, it should be connected!



If the photo eye sensors are correctly mounted and aligned, the function 'photo eye' is recognized automatically during programming!

Plug the opener into outlet. Opener runs a self-test; all 8 LEDs will glow and opener light(s) will illuminate for approximately 2 seconds. When the light(s) is off and LED  is illuminated the opener is in normal operating mode.

#### ADJUSTMENT BUTTONS:

All settings and adjustments can be made with the three adjustment buttons.

Use  and  to change settings of chosen program menu.  
 to store menu setting and go to next menu.

The programming is cancelled if none of the three buttons (, , ) is actuated during a time period of more than 120 sec.

All functions saved before with button  remain unchanged.

When programming is cancelled, LED  is flashing.

Press and release button , the error message 7 is displayed.

#### Advice:

In case of a malfunction the control light MALFUNCTION  is flashing.

Press and release button , the error message is displayed.

To determine the error number combine numbers of the flashing LED's. (See section 19 "Error Messages" on p.35).

**Advice:**

All menus can be reset by a RESET function to the original values set by factory.  
Reset is activated by pressing P, and together for more than 30 seconds.

## 8-4. BASIC SETTINGS

### Menu Overview:

1. Set door OPEN position
2. Set door CLOSED position
3. Program hand transmitter

### To Set Up the Opener:

#### Menu 1

##### SET DOOR OPEN POSITION 2

1. Press P for 2 seconds until LED blinks and all others are illuminated.
2. To move the garage door to desired fully OPEN position press & hold the until desired DOOR OPEN position is reached.  
For fine adjustment use the (OPEN) or (CLOSE) buttons.

**Advice:**

The reference point has to be passed one time.

will light up briefly when reference point has to be passed one time.

3. Press P to store open position in memory. It also advances to next setting **Menu 2**.

#### Menu 2

##### SET DOOR CLOSE POSITION 4

1. LED blinks and all others are illuminated.
2. To move the garage door to desired fully CLOSED position press & hold the until desired DOOR CLOSE position is reached.  
For fine adjustment use the (OPEN) or (CLOSE) buttons.

**Advice:**

The reference point has to be passed one time.

will light up briefly when reference point has to be passed one time.

3. Once door position is correct press P to store setting in memory and go to **Menu 3**.

#### Menu 3

##### PROGRAM THE TRANSMITTER CODE

1. LED blinks and all others are illuminated.
2. Press transmitter button until LED blinks rapidly.
3. Press P to store multi-bit transmitter code and to finish basic programming. LEDs will automatically turn off starting at LED and ending at LED .  
The opener is now in operational (normal) mode .

##### MAKING ADJUSTMENTS

This is useful to know if you want to change only one setting, without changing any of the other adjustments. Simply enter the adjustment mode by pressing and holding the P button for approximately 2 seconds, then press and release P repeatedly until your particular adjustment is reached. This bypasses the unneeded adjustments, and takes you right to the adjustment you want. When your adjustment or setting is complete, simply press P as many times as needed to bypass the remaining steps and exit out of the program, returning the opener to normal mode.

Run the opener (with door engaged) without interruption two complete cycles from position 'DOOR CLOSED' to position 'DOOR OPENED' and vice versa.

During these two learning travels the opener determines the maximum push and pull force which is required to move the door. After two complete cycles the opener is ready for operation. These settings remain unchanged even if power supply is interrupted but they can, if necessary, be changed as described in "Advanced Settings".



**Attention:**

If the opener cuts out during the test run and LED 8 and LED 2 are flashing quickly (error number 10/automatic cut out) set the automatic cut out. See section 8-5 "Advanced Settings" Level 2 Menu 2 and 3.

##### TEST THE OPENER:

Press button . The door must travel to the 'door open' position.

Press button . The door must travel to the 'door closed' position.

Shortly press the button on your hand transmitter. The opener moves the door into 'OPEN' direction.

Press the button on your hand transmitter again during the opener run. The door must stop.

Press button again. Door begins to move in the opposite direction.

## 8-5. ADVANCED FEATURES



**Attention:**

Programming the advanced features of this operator must only be undertaken by fully trained and qualified personnel. Please contact your dealer for details.

##### ADVANCED PROGRAMMING FEATURES:

- Advanced settings (Level 2)
- Automatic closing (Level 3)
- External Lighting (Level 4)